

1. FRAME COMPONENTS

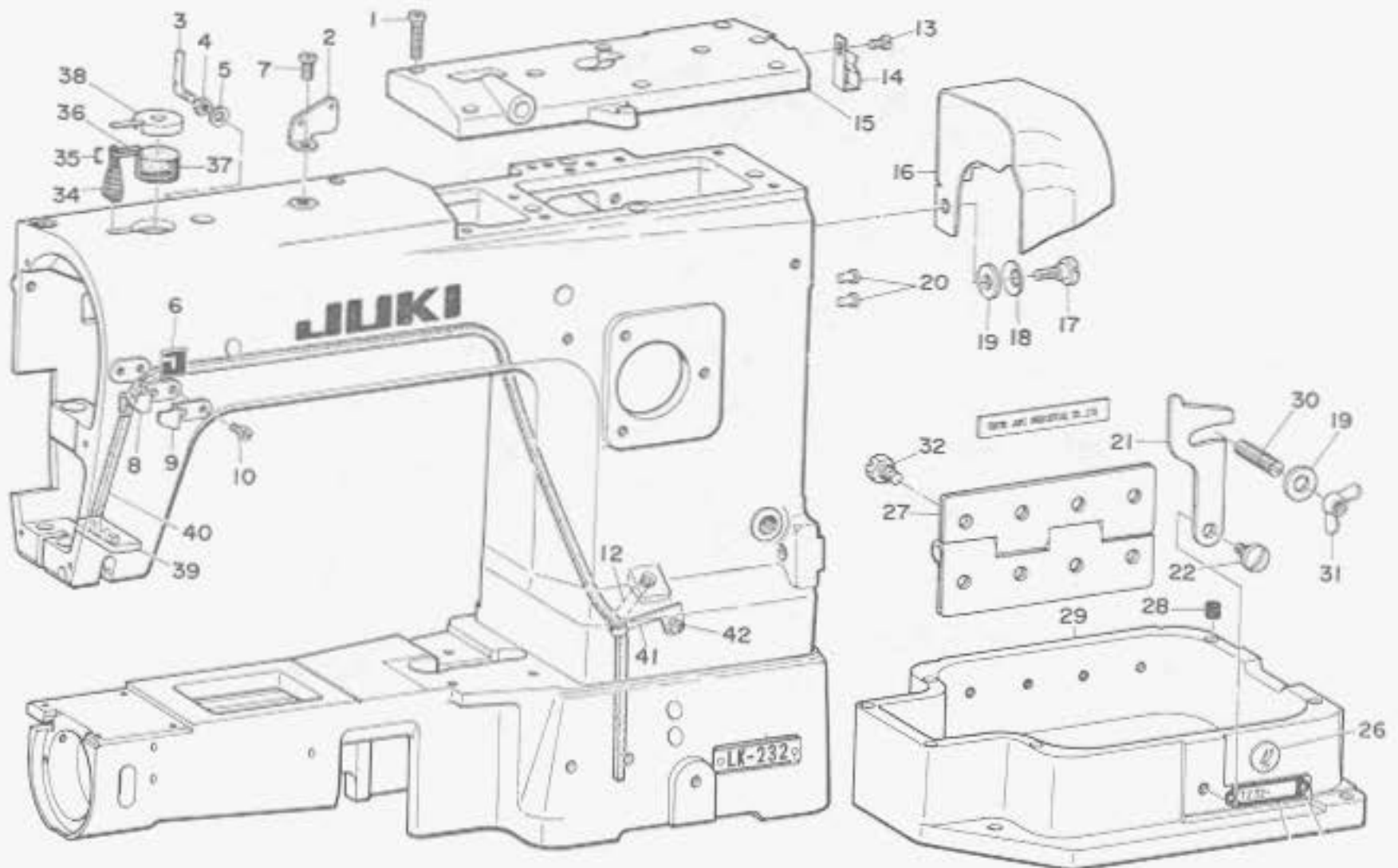

Ref. No.	Part No.	Description	Amt. Req.	Ref. No.	Part No.	Description	Amt. Req.
1	SS-6151920-SP	Clamp screw, for top cover	4	26	B-1116-232-000	Stitch number indicator, for 42 stitches	1
2	B-1111-232-000	Frame thread guide, upper	1	27	B-1105-232-0A0	Hinge complete	1
3	B-1114-232-000	Frame thread eyelet, upper	1	28	B-1103-232-000	Rubber cushion	6
4	NS-6110530-SP	. . . Nut	1	29	B-1104-232-000	Machine sub-base	1
5	WP-0501016-SD	. . . Washer	1	30	B-1110-232-000	Stop screw, for catch	1
6	B-1178-092-000	JUKI mark	1	31	B-2532-232-000	. . . Wing nut	1
7	SS-7151210-SP	Clamp screw, for thread guide, upper	1	32	SD-0800351-SP	Clamp screw, for hinge	8
8	B-1118-232-000	Frame thread guide, lower	1	34	B-1230-232-000	Oil dripped cloth	1
9	B-1119-232-000	. . . Spring	1	35	B-1419-026-000	Oil wick holder	2
10	SS-7090910-SP	. . . Clamp screw	2	36	CO-3030000-00	Oil wick	1
12	B-1125-232-000	Oil supply tube, for oscillating rock shaft	1	37	B-1228-232-000	Oil felt	1
13	SS-7110710-SP	Clamp screw, for belt guard spring	1	38	B-1227-232-000	. . . Cover	1
14	B-1122-232-000	Belt guard spring	1	39	B-1408-232-000	Oil felt, for needle bar crank guide	1
15	B-1107-232-000	Frame top cover	1	40	B-3541-012-000	Oil return felt	1
16	B-1120-232-000	Belt guard	1	41	B-3506-761-000	. . . Holder	1
17	SD-0790511-SP	. . . Clamp screw	1	42	SS-7110710-SP Screw	1
18	B-1121-232-000	. . . Spring washer	1				
19	WP-0850002-SD	. . . Washer	2				
20	B-1223-232-000	Positioning pin, for arm shaft	2				
21	B-1109-232-000	Catch (securing machine arm to bed)	1				
22	SD-0800352-SP	. . . Clamp screw	1				

2. FACE PLATE, THREAD CONTROLLER & BOBBIN THREAD WINDER COMPONENTS

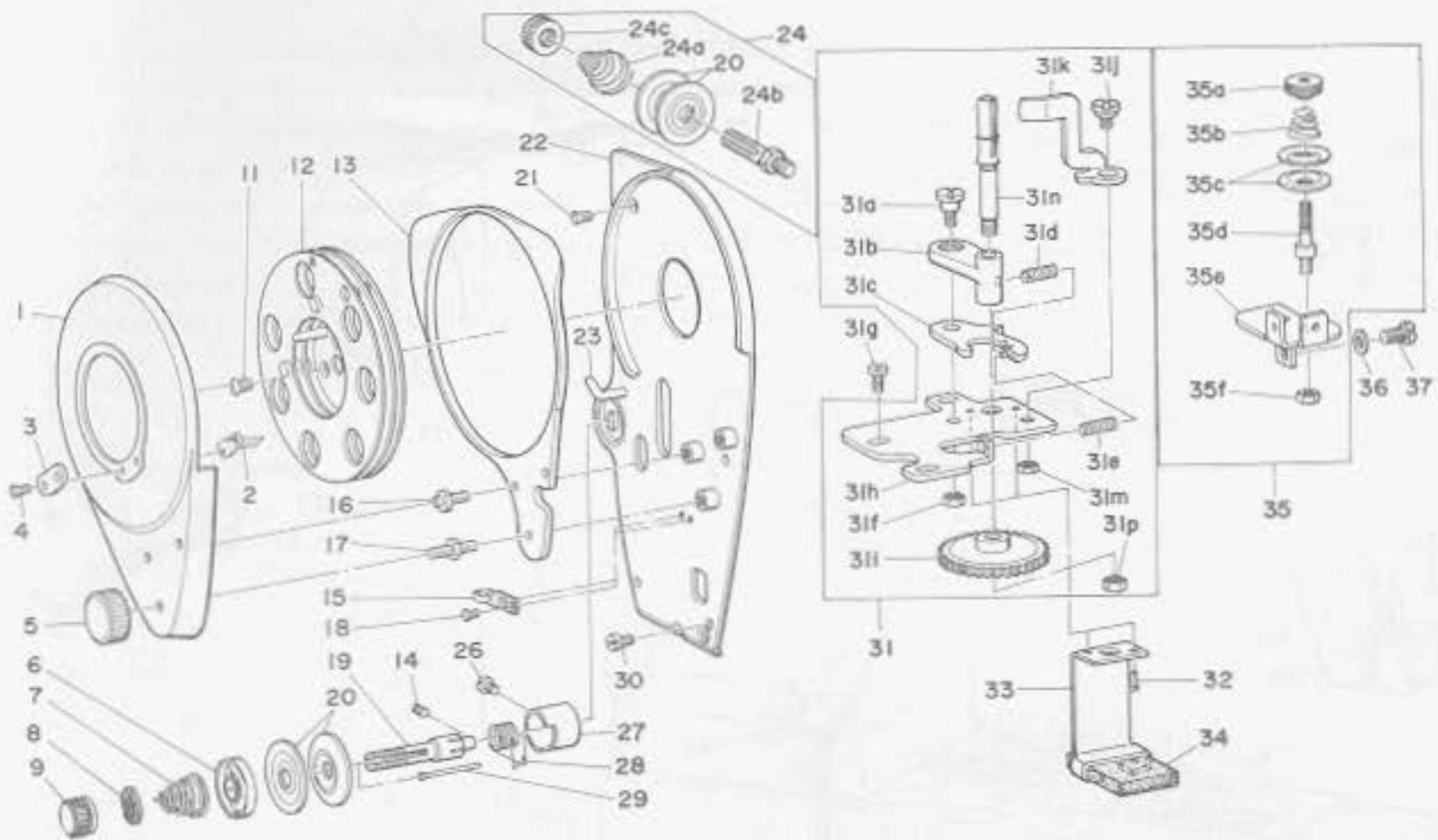

Ref. No.	Part No.	Description	Amt. Req.	Ref. No.	Part No.	Description	Amt. Req.
1	B-3102-232-000	Face plate cover	1	* 31	B-3201-232-0A0	Bobbin winder complete	1
2	B-3120-232-000	Take-up thread trimmer	1	31a	B-3205-232-000	Hinge screw, for frame	1
3	B-3121-232-0001	. . . Retainer	1	31b	B-3204-232-000	Bobbin winder frame	1
4	SS-2060410-SP	. . . Clamp screw	2	31c	B-3206-232-000	Bobbin winder tension bracket	1
5	B-3109-232-000	Face plate cover knob	1	31d	B-3208-232-000	. . . Spring (short)	1
*	B-3113-232-0A0	Tension No. 2 assembly	1	31e	A-3222-958-000	Bobbin winder spring (long)	1
6	B-3132-552-000	Tension disc holder	1	31f	NS-6110310-SP	Nut, for hinge screw	1
7	B-3114-232-000	Tension spring No. 2	1	31h	B-3201-232-000	Bobbin winder base	1
8	B-3120-125-000	Tension disc stop	1	31i	B-3203-232-000	Bobbin winder worm wheel	1
9	B-3116-125-000	Tension nut	1	31j	SD-0720193-SP	Hinge screw, for trip latch	1
19	B-3113-232-000	Tension post No. 2	1	31k	B-3210-232-000	Bobbin winder trip latch	1
20	B-3126-012-000	Tension disc	2	31m	NS-6110310-SP	Nut, for trip latch hinge screw	1
29	B-3111-232-000	Tension release pin	1	31n	B-3202-232-000	Bobbin winder spindle	1
11	SS-2110930-SP	Clamp screw, for thread take-up disc	3	31p	NS-6120310-SP	Clamp nut, for bobbin winder worm wheel	1
12	B-1901-232-0A0	Thread take-up disc complete	1	31g	SS-7110910-SP	Clamp screw, for bobbin winder	3
13	B-3106-232-000	Thread take-up disc frame	1	32	B-3211-232-000	Positioning pin, oil supply bracket	2
14	SS-8090870-SP	Clamp screw, for tension post	1	33	B-3212-232-000	Worm wheel oil supply bracket	1
15	B-3104-232-000	Face plate thread guide	1	34	B-3213-232-000	. . . Oil felt	1
16	B-3108-232-000	Hinge screw (A), for frame	2	* 35	B-3217-232-0A0	Bobbin winder tension bracket complete	1
17	B-3122-232-000	Hinge screw (B), for frame	1	35a	B-3216-047-000	. . . Tension nut	1
18	SS-2060310-SP	Clamp screw, for face plate thread guide	2	35b	B-3218-232-000	. . . Tension spring	1
21	SS-2090520-SL	Clamp screw (B), for face plate	1	35c	B-3214-047-000	. . . Tension disc	2
* 22	B-3101-232-0B0	Face plate complete	1	35d	B-3219-232-000	. . . Tension post	1
* 24	B-1115-232-0A0	Tension controller No. 1	1	35e	B-3217-232-000	. . . Tension bracket	1
24a	B-1115-232-000	Tension spring No. 1	1	35f	NS-6110310-SP	. . . Tension post nut	1
20	B-3126-012-000	Tension disc No. 1	2	36	WP-0480856-SP	Washer, for tension bracket	1
24b	B-3123-352-000	Tension post No. 1	1	37	SS-7110840-SP	Clamp screw, for tension bracket	1
24c	B-3125-012-000	Tension nut No. 1	1				
26	SS-7080410-SP	Clamp screw, for tension sleeve	1				
27	B-3112-232-000	Tension sleeve	1				
28	B-3128-232-000	Take-up spring	1				
30	SS-3090610-SP	Clamp screw (A), for face plate	3				

3. MAIN SHAFT & NEEDLE BAR COMPONENTS

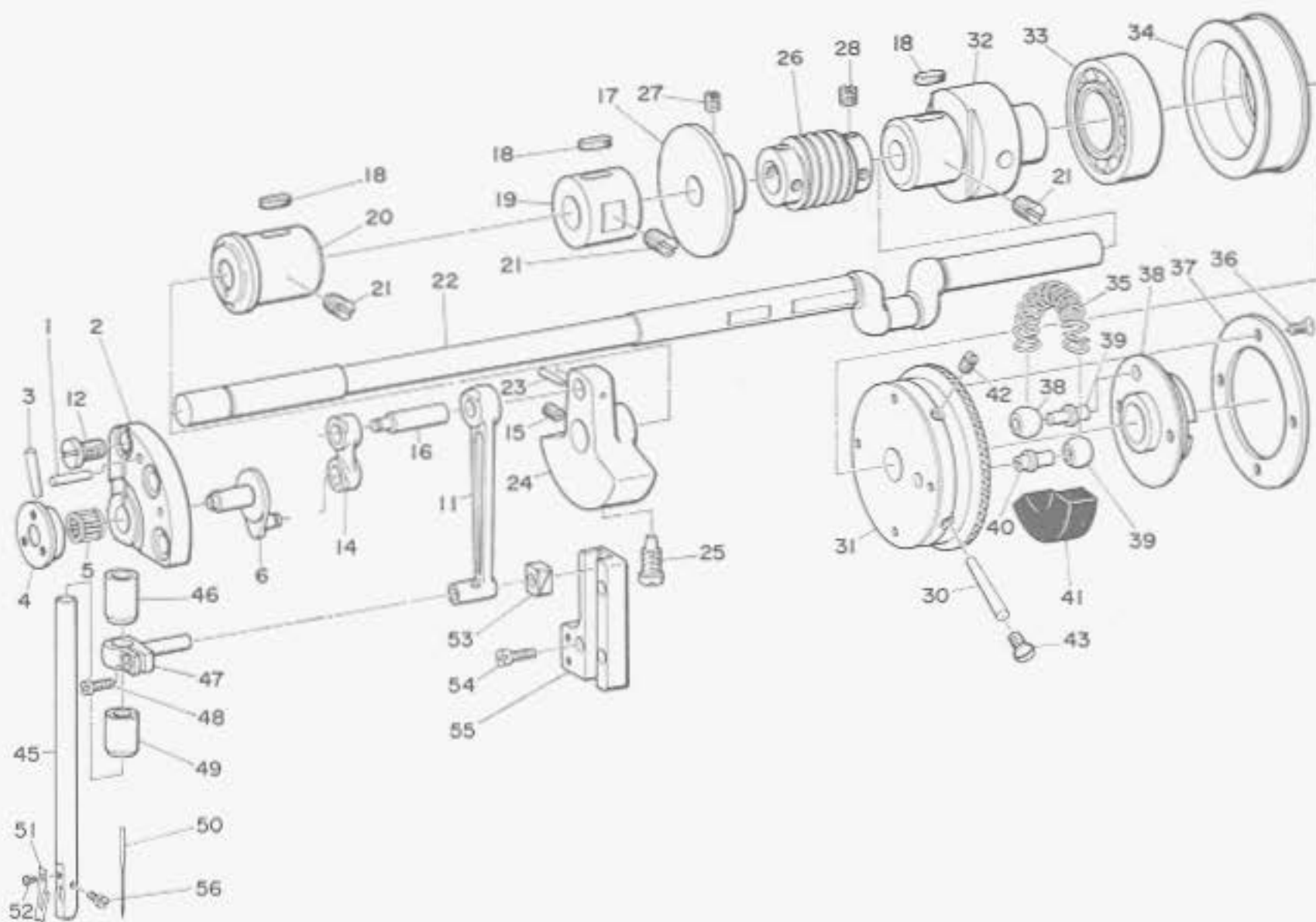

Ref. No.	Part No.	Description	Amt. Req.	Ref. No.	Part No.	Description	Amt. Req.
1	PT-0401800-SO	Positioning pin, for needle bar crank	2	31	B-1207-232-0A0A	Driving pulley (with pin)	1
*	B-1217-232-0A0	Needle bar crank assembly	1	32	B-1204-232-000	Main shaft bushing, rear, complete	1
2	B-1217-232-000	Needle bar crank	①	33	B-1206-232-000	Ball bearing, for idler pulley	1
3	PT-0302000-SO	Positioning pin, for thrust plate	①	34	B-1205-232-000	Idler pulley	1
4	B-1220-232-000	Thrust plate	①	35	B-1211-232-000	Stop cam spring	①
5	B-1219-232-E00	Needle bearing hinge stud	①	36	SS-2110920-TP	Clamp screw, for cap ring	4
6	B-1218-232-000A	Needle bar crank hinge stud	①	37	B-1213-232-000	Stop cam cap ring	1
11	B-1215-232-000	Needle bar connecting link	1	38	B-1208-232-000	Stop cam	1
12	SS-6201940-SP	Clamp screw, for needle bar crank	3	39	B-1210-232-000	Stop cam hinge pin check block	2
14	B-1221-232-000	Needle bar crank connecting link	1	40	B-1209-232-000	Stop cam hinge pin	1
15	SS-8150760-TP	Clamp screw (B), for counterweight	1	41	B-1212-232-000	Bakelite segment	1
16	B-1216-232-000A	Needle bar connecting link hinge pin	1	42	SS-8150410-TP	Clamp screw, for driving pulley	1
17	B-3215-232-000	Bobbin winder friction wheel	1	43	SS-5150540-SP	Oil seal screw, for driving pulley	3
18	B-1702-012-000	Oil felt, for main shaft bushing	3	45	B-1401-232-000	Needle bar	1
19	B-1203-232-000	Main shaft bushing, center	1	46	B-1405-232-000	. . . Upper bushing	1
20	B-1202-232-000	Main shaft bushing, front	1	47	B-1403-232-000	Needle bar connection	1
21	SS-8701140-SP	Clamp screw, for main shaft bushing	4	48	SS-7091110-TP	. . . Clamp screw	①
22	B-1201-232-000	Main shaft	1	49	B-1406-232-000	Lower bushing, for needle bar	1
23	PT-0251800-SH	Positioning pin, for counterweight	1	50	MLQ-500B1800	Needle (LQx5, #18)	1
24	B-1214-232-000	Counterweight	1	51	B-2018-232-000	Thread nipper	1
25	SS-7681750-TP	. . . Clamp screw (A)	1	52	SS-5060310-SP	. . . Screw	1
26	B-2207-232-000	Feed cam driving worm	1	53	B-1414-232-000	Needle bar connection slide block	1
27	SS-8150710-SP	Clamp screw, for friction wheel	2	54	SS-6091210-TP	Screw, for needle bar crank guide	3
28	SS-8660610-TP	Clamp screw, for feed cam driving worm	8	55	B-1404-232-000	Needle bar crank guide	1
30	PT-0402200-C0	Positioning pin, for driving pulley	1	56	SS-7080510-SP	Needle set screw	1

4. PRESSER BAR & LIFTING LEVER COMPONENTS

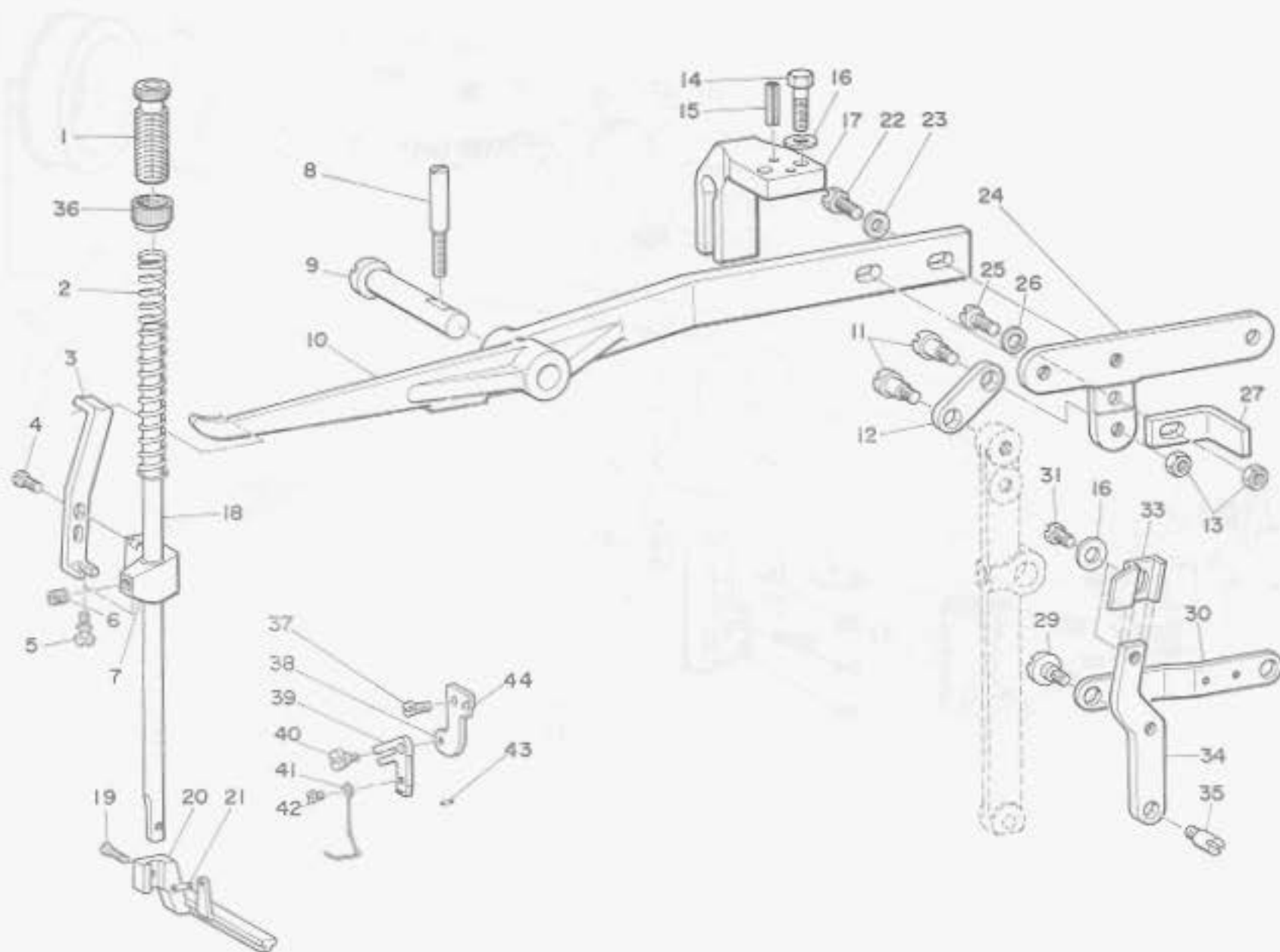

Ref. No.	Part No.	Description	Amt. Req.	Ref. No.	Part No.	Description	Amt. Req.
1	B-1509-012-000	Presser spring regulator	1	21	B-2105-232-000	Positioning pin, for thread wiper wire	1
2	B-1518-232-000	Presser bar spring	1	22	SS-9151630-CP	Set screw, for chain suspending holder	2
3	B-1505-232-000	Lifting bracket link	1	23	WP-0621016-SD	Washer	2
4	SS-6111010-TP	Clamp screw	2	24	B-1507-232-000	Chain suspending holder	1
5	B-1523-232-000	Regulating screw	1	25	SS-7151210-SK	Set screw, for lifting lever bracket	1
6	SS-8150410-SP	Clamp screw, for presser bar lifting bracket	1	26	WP-0651056-SD	Washer	1
7	B-1504-232-000	Presser bar lifting bracket	1	27	B-1521-232-000	Lifting lever bracket	1
8	B-1524-232-000	Clamp screw, for lifting lever pin	1	29	SD-0790303-SP	Hinge screw, for lifting lever link	2
9	B-1516-232-000	Lifting lever pin	1	30	B-1522-232-000	Lifting lever link	1
10	B-1506-232-000	Lifting lever	1	31	SS-9150860-SP	Set screw, for lifting lever link	1
11	SD-0800553-SP	Hinge screw, for tripping lever link	2	33	B-1520-232-000	Lifting lever stop	1
12	B-1510-232-000	Knife bar tripping lever link	1	34	B-1519-232-000	Lifting lever stop bracket	1
13	NS-6150310-SP	Nut, for tripping lever link & lifting lever bracket	3	35	B-1525-232-000	Hinge screw	1
14	SS-9152130-CP	Clamp screw, for lifting lever guide	2	36	NS-2820850-SP	Lock nut	1
15	PS-0500202-KP	Positioning pin, for lifting lever guide	2	37	SS-7120910-SP	Screw	1
16	WP-0621016-SD	Slip washer, for lever guide & chain	3	38	B-2104-232-000	Wiper bracket	1
17	B-1515-232-000	Lifting lever guide	1	39	B-2102-232-000	Wiper link	1
18	B-1502-232-000	Presser bar	1	40	SD-0550271-TP	Hinge screw	1
19	SS-7091110-TP	Clamp screw, for clamp foot lifting lever	1	41	B-2101-232-000	Wiper	1
20	B-1501-232-000	Clamp foot lifting lever	1	42	SS-6090420-SP	Screw	1
				43	B-2106-232-000	Pin	2
				44	B-2107-232-000	Pin	1

5. THREAD NIPPER, WIPER & SHUTTLE DRIVER SHAFT COMPONENTS

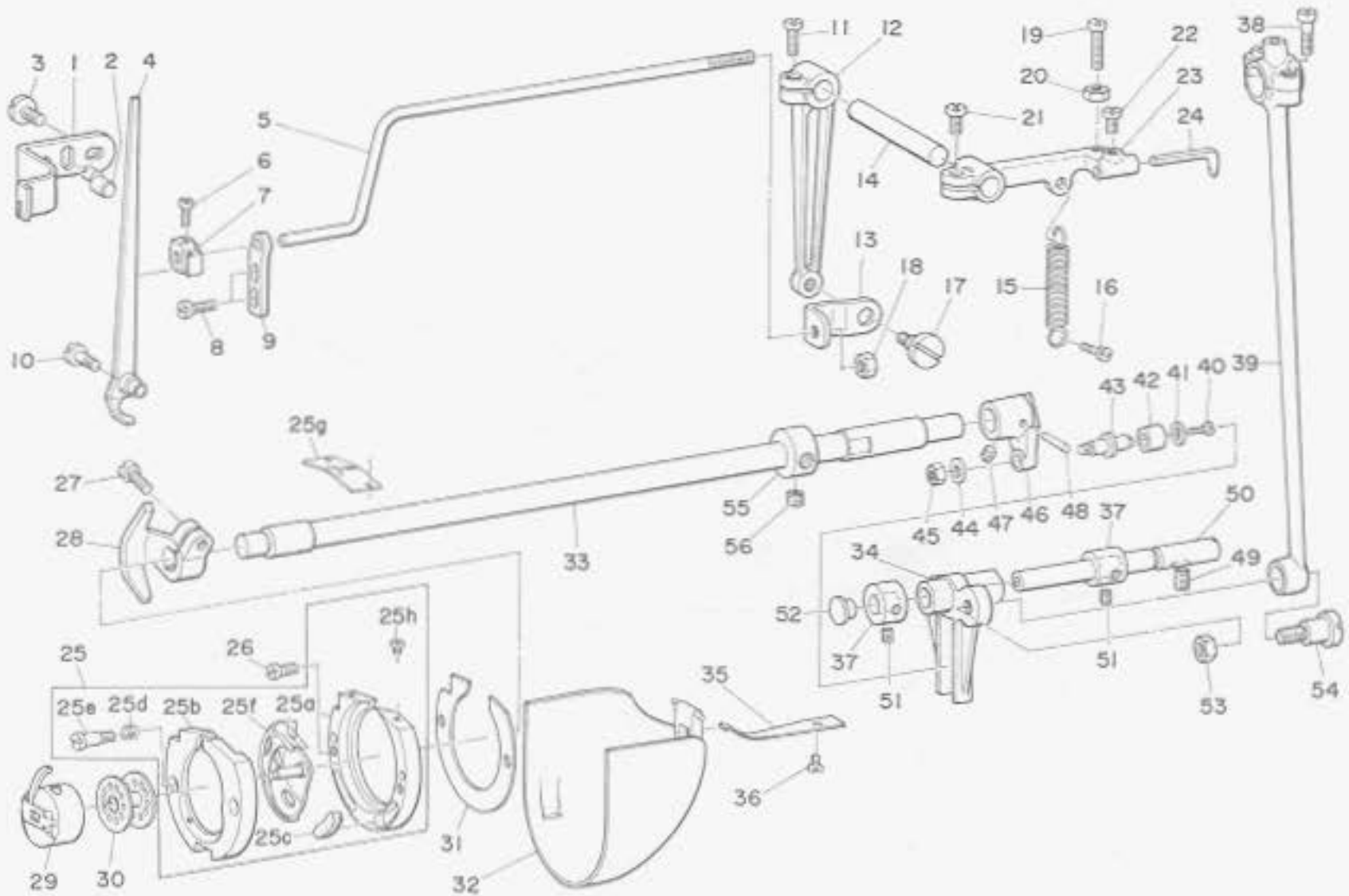

Ref. No.	Part No.	Description	Amt. Req.	Ref. No.	Part No.	Description	Amt. Req.
*4	B-2015-232-0A0	Thread nipper lever complete	1	26	SS-7110860-SP	Clamp screw, for shuttle race	2
10	SD-0400841-SP	Hinge screw, for thread nipper	①	28	B-1810-232-000	Shuttle driver (with screw)	1
5	B-2020-232-000	Thread nipper rod	1	27	SS-6121212-TP	Clamp screw, for shuttle driver	①
7	B-2013-232-000	Thread nipper rod extension	1	29	B-1836-232-0A0	Bobbin case	1
6	SS-6080810-SP	Clamp screw, for extension	1	30	A-9117-001-000	Bobbin	1
8	SS-7091110-SP	Clamp screw, for bearing bracket	2	31	B-9101-232-000	Spacing washer	1
9	B-2014-232-000	Thread nipper rod bearing bracket	1	32	B-1824-232-0A0	Cylinder arm cap complete	1
12	B-2010-232-000	Thread nipper crank	1	33	B-1809-232-000	Shuttle driver shaft	1
11	SS-7111120-SP	Binding screw, for thread nipper crank	1	34	B-1804-232-000	Oscillating rock shaft	1
13	B-2011-232-000	Thread nipper rod joint	1	35	B-1821-232-000	Cylinder arm cap spring	1
14	B-2009-232-000	Thread nipper stud	1	36	SS-7090510-SP	. . . Clamp screw	1
1	B-2021-232-000A	Thread nipper stopper	1	*37	CS-0791016-SH	Thrust collar, for oscillating rock	2
2	B-2022-232-000A	. . . Adjusting shaft	1	38	SS-7111310-SP	Clamp screw, for connecting rod cap	②
3	SS-6111140-SP	. . . Screw	2	39	B-1801-232-0A0	Shuttle drive connecting rod	1
15	B-2007-232-000	Tension spring, for tripping lever	1	40	SS-6080610-TP	End screw, for shuttle driver shaft crank	1
16	SS-6111040-SP	. . . Suspension screw	1	41	B-1829-232-000	. . . Washer	1
17	SD-0790303-SP	Hinge screw, for joint	1	42	B-1828-232-000	Slide roller, for shuttle drive shaft crank	1
18	NS-6620310-SP	Nut, for thread nipper rod	1	43	B-1827-232-000	Slide roller stud	1
19	SS-6111610-SP	Set screw, for tripping lever	1	44	WP-0501016-SD	. . . Thrust washer	1
20	NS-6110530-SP	. . . Nut	1	45	NS-6120310-SP	. . . Nut	1
21	SS-9151120-CP	Clamp screw, for tripping lever	1	46	B-1806-232-000	Shuttle driver shaft crank	1
22	SS-7110740-TP	Clamp screw, for finger	1	47	SS-8110410-TP	. . . Stop screw	1
23	B-2001-232-000	Thread nipper tripping lever	1	48	PT-0301600-SO	. . . Positioning pin	1
24	B-2002-232-000	. . . Finger	1	49	SS-8150710-SP	Clamp screw, for oscillating rock shaft hinge pin	1
*25	B-1812-232-0B0	Shuttle race complete (with shuttle)	1	50	B-1805-232-000	Oscillating rock shaft hinge pin	1
	B-1812-232-0A0	Shuttle race complete	(1)	51	SS-8110520-TP	Clamp screw, for thrust collar	④
25a	B-1812-232-000	Shuttle race	①	52	B-1807-232-000	Cap, for hinge pin	1
25b	B-1813-232-000	Shuttle race ring	①	53	NS-6660430-SP	Nut, for hinge screw	1
25c	B-1814-232-000	Oil felt, for shuttle	②	54	SD-1030931-SP	Hinge screw, for connecting rod	1
25d	B-1815-232-000	Pressure spring, for ring	②	55	CS-1201011-SH	Thrust collar, for shuttle driver shaft	1
25e	SD-0500803-SL	Clamp screw, for ring	②	56	SS-8660530-TP	. . . Clamp screw	2
25f	B-1823-232-000	Shuttle	①				
25h	SS-6080340-SP	Clamp screw, for shuttle race spring	①				
25g	B-1816-232-000	Shuttle race spring	1				

6. FEED CAM COMPONENTS

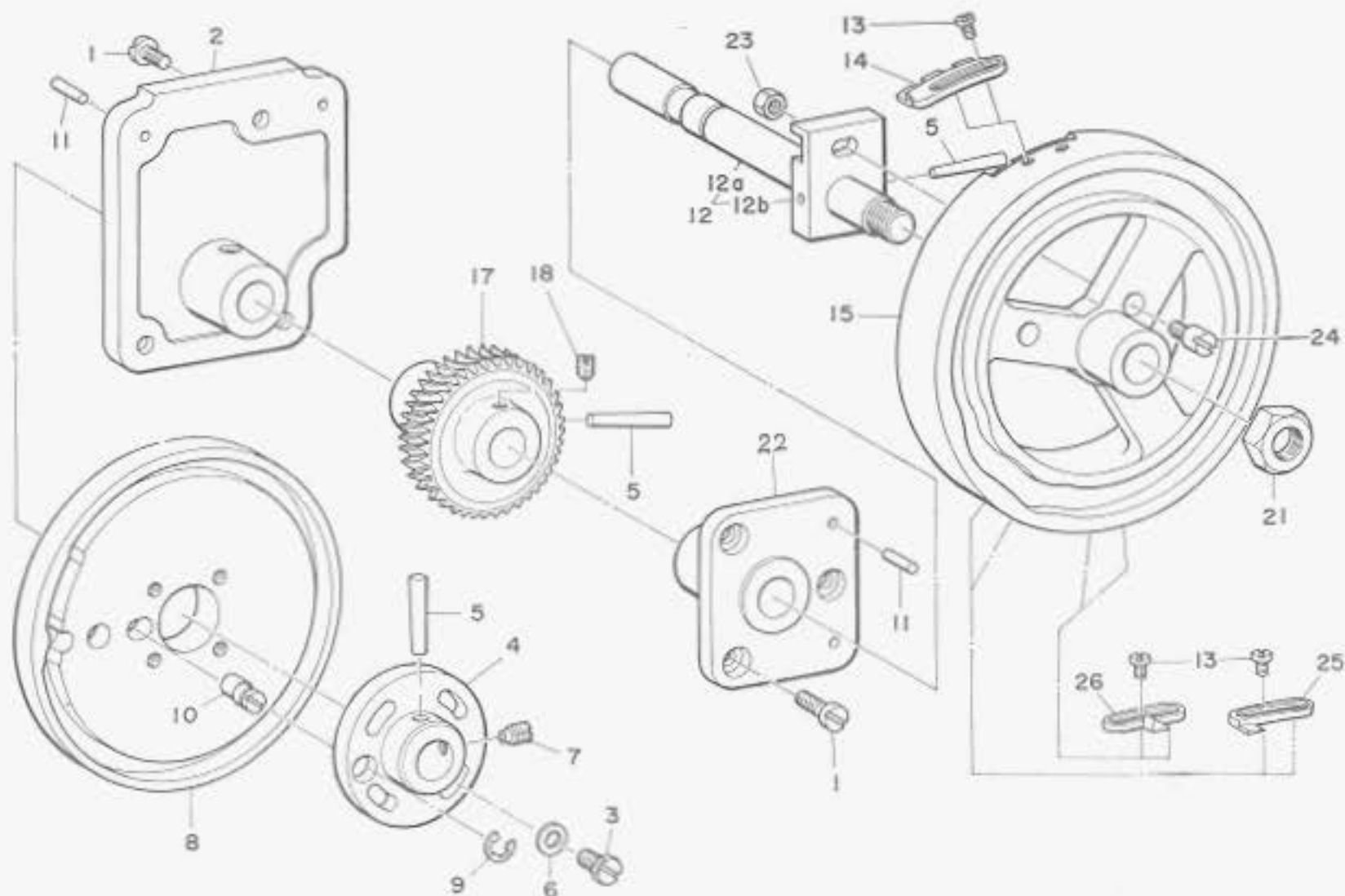

Ref. No.	Part No.	Description	Amt. Req.	Ref. No.	Part No.	Description	Amt. Req.
1	SS-7151210-SP	Clamp screw, for bearing bracket	6	13	SS-7090520-TP	Clamp screw, for tripping segment	6
2	B-2204-232-000	Worm shaft bearing bracket, rear	1	14	B-2220-232-000	Thread nipper tripping segment, for 42 & 21 stitches	1
3	SS-9151630-CP	Clamp screw, for knife cam	4	15	B-2209-232-000	Feed cam, for 42 stitches	1
4	B-2212-232-000	Knife cam positioning flange	1	17	B-2206-232-000	Feed cam driving worm wheel	1
5	PT-0503200-SH	. . . Positioning pin	4	18	SS-8151150-TP	. . . Clamp screw	2
6	WP-0621016-SD	. . . Washer	4	21	NS-6361040-SP	Lock nut, for feed cam	1
7	SS-8151150-TP	. . . Clamp screw	1	22	B-2205-232-000	Worm wheel shaft bearing	1
8	B-2211-232-000	Knife cam, for 42 stitches	1	23	NS-6150540-SP	Nut, for position stud	1
9	RE-0600000-KO	Washer, for hinge stud	1	24	B-2202-232-000	Feed cam position stud	1
10	B-2218-232-000	Knife cam regulating hinge stud	1	25	B-2213-232-000	Stop tripping segment (A)	1
11	PT-0401800-SO	Positioning pin, for bearing bracket	4	26	B-2214-232-000	Stop tripping segment (B)	1
12	B-2201-232-0A0	Worm wheel shaft complete	(1)				
12a	B-2201-232-000	Worm wheel shaft	1				
12b	B-2203-232-000	Lock plate, for feed cam	1				

7. KNIFE BAR & NEEDLE PLATE COMPONENTS

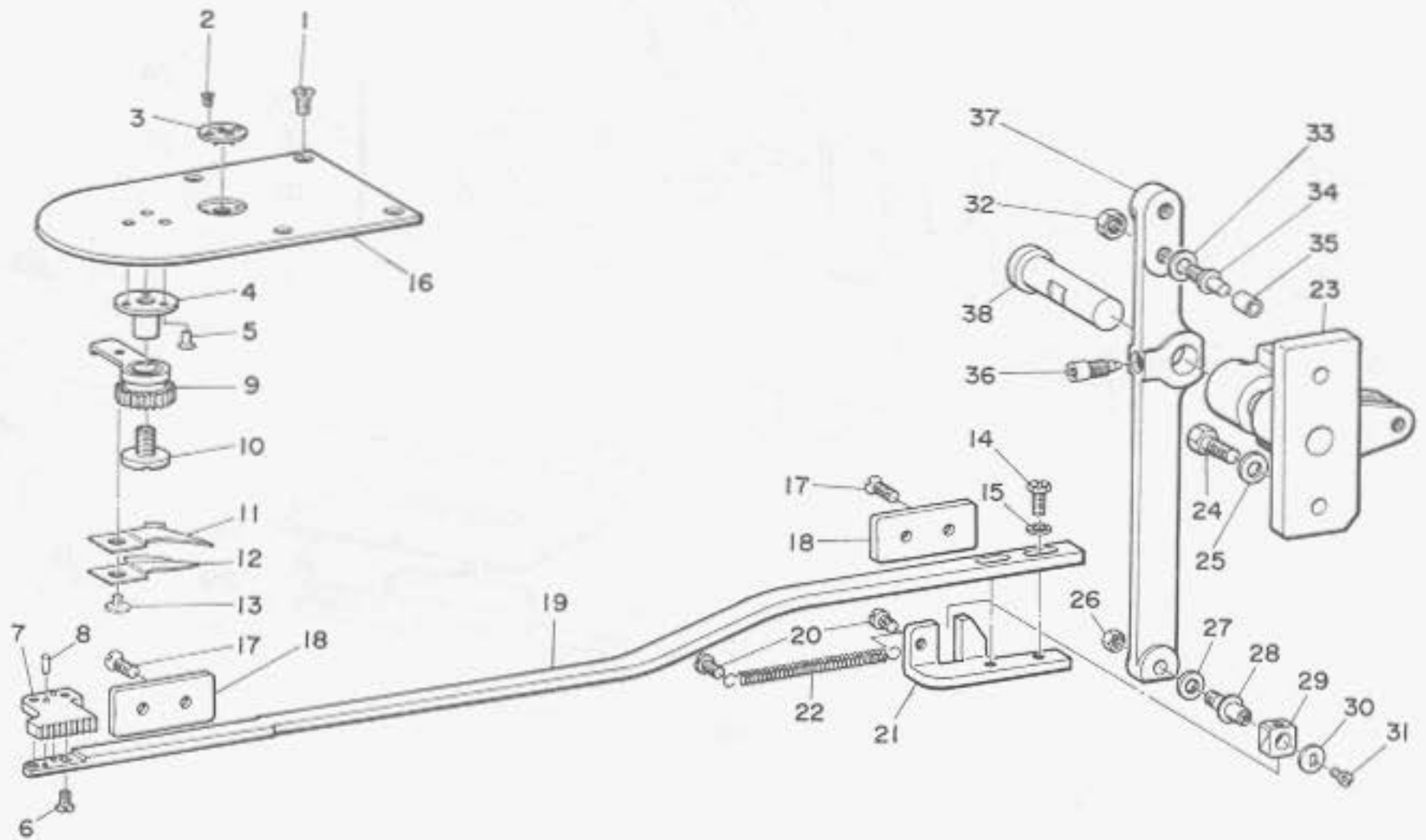

Ref. No.	Part No.	Description	Amt. Req.	Ref. No.	Part No.	Description	Amt. Req.
1	SS-1110640-TP	Clamp screw, for needle plate	4	21	B-2411-232-000	Knife bar tripping fork	1
2	SS-2060220-SP	Clamp screw, for needle hole guide	2	22	B-2416-232-000	Knife bar tension spring	1
3	B-2426-232-000	Needle plate needle hole guide	1	23	B-2407-232-000	Knife bar tripping lever bearing	1
4	B-2426-232-000	Pinion stud, for stationary knife	1	24	SS-9151630-CP	Clamp screw	2
5	B-2429-232-000	Tapered pin	3	25	WP-0621016-SD	Washer	2
6	SS-6090510-SP	Clamp screw, for stationary knife	2	26	NS-6120310-SP	Nut	1
7	B-2414-232-000	Stationary knife	1	27	WP-0501016-SD	Washer, for slide block stud	1
8	B-1826-232-000	Positioning pin	2	28	B-1827-232-000	Slide block stud, for tripping lever	1
9	B-2432-232-0A0	Knife holder pinion stud bracket	1	29	B-1414-232-000	Slide block, for tripping lever	1
10	SS-7161040-SP	Clamp screw, for pinion stud	1	30	B-1829-232-000	Washer	1
11	B-2424-232-000	Bobbin thread knife	1	31	SS-6080610-TP	Set screw	1
12	B-2423-232-000	Needle thread knife	1	32	NS-6150540-SP	Nut, for roller stud	1
13	SS-7080310-SP	Clamp screw, for knife	1	33	WP-0621016-SD	Washer, for roller stud	1
14	SS-9110920-CP	Clamp screw, for knife bar tripping fork	2	34	B-2402-232-000	Roller stud, for tripping lever	1
15	WS-0451040-KP	Washer	2	35	B-2403-232-000	Roller, for tripping stud	1
16	B-2425-232-000	Needle plate	1	36	SS-6151142-TP	Clamp screw, for tripping lever	1
17	SS-2110920-TP	Clamp screw, for position bracket	4	37	B-2401-232-000	Knife bar tripping lever	1
18	B-2413-232-000	Knife bar position bracket	2	38	B-2408-232-000	Knife bar tripping lever stud	1
19	B-2410-232-000	Knife bar	1				
20	SS-7110860-SP	Spring suspension screw	2				

8. WORK CLAMP & FEED PLATE CARRIER BAR COMPONENTS

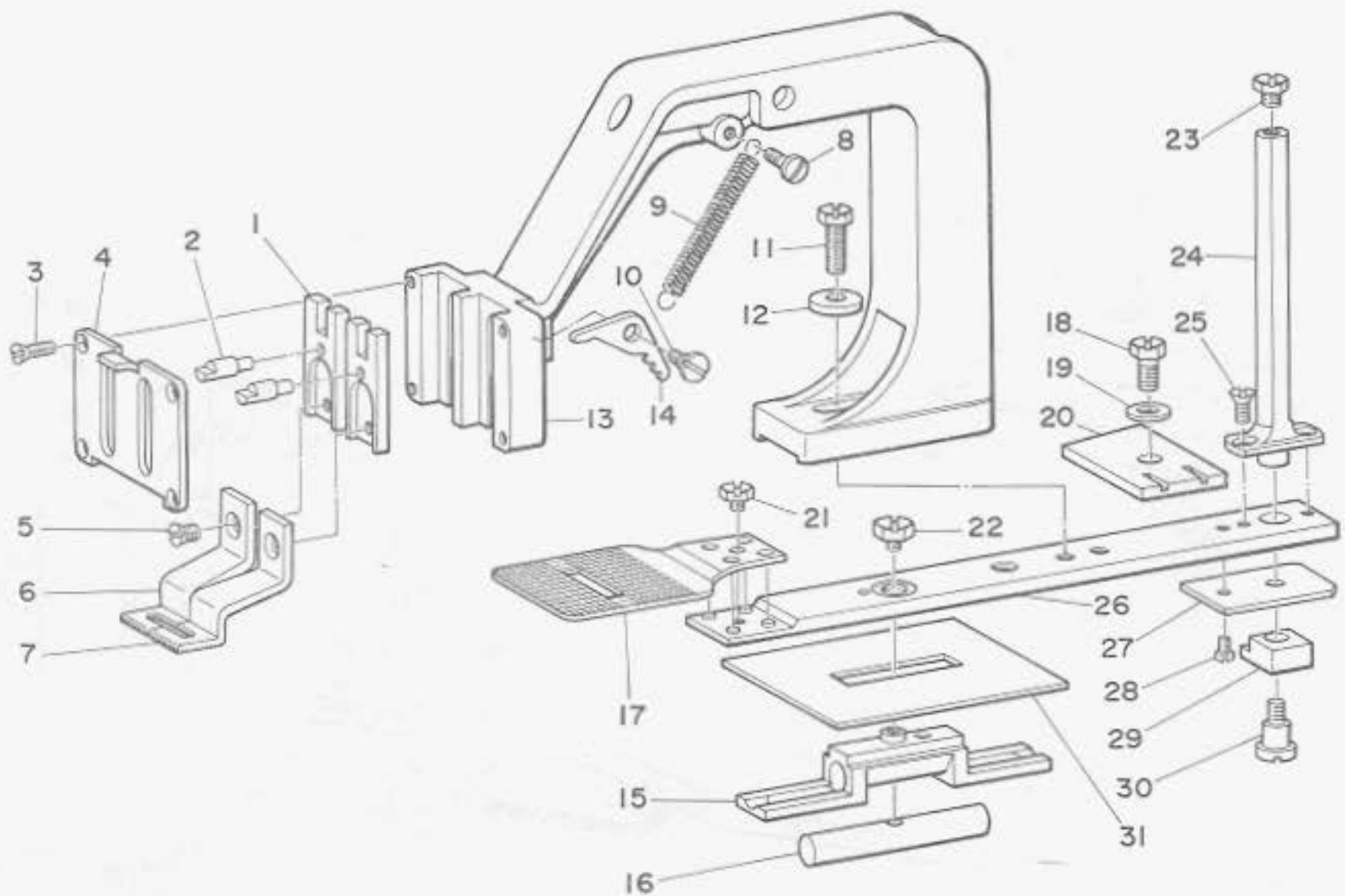

Ref. No.	Part No.	Description	Amt. Req.	Ref. No.	Part No.	Description	Amt. Req.
1	B-2523-232-000	Work clamp foot bracket	2	17	B-2517-232-000	Feed plate	1
2	B-2524-232-000	. . . Positioning pin	2	18	SS-9151120-CP	Clamp screw, for guide plate	1
3	SS-2111140-SP	Clamp screw, for face plate	4	19	WP-0621016-SD	. . . Washer	1
4	B-2525-232-000	Work clamp face plate	1	20	B-2519-232-000	Feed plate carrier bar guide plate	1
5	SS-1110640-TP	Clamp screw, for work clamp foot	2	21	SS-9110463-CP	Clamp screw, for feed plate	1
6	B-2550-232-0A0	Work clamp foot complete	1	22	SS-9110460-CP	Clamp screw, for feed across driving block	1
7	B-2551-232-000	Work clamp foot, left	①	23	SS-9110543-SP	Stop screw, for feed regulator post	1
8	B-2550-232-000	Work clamp foot, right	①	24	B-2505-232-000	Feed regulator post	1
9	SD-0480251-SP	Clamp screw, for pressure spring	2	25	SS-1110810-SP	. . . Clamp screw	2
10	B-2548-232-000	Pressure spring	2	26	B-2512-232-0A0	Feed plate carrier bar	1
11	SD-0640241-SP	Hinge screw, for work clamp hook	2	27	B-2515-232-000	Feed plate carrier bar guide plate, rear	1
12	SS-9151440-CP	Clamp screw, for work clamp frame	1	28	SS-7080510-SP	. . . Stop screw	1
13	WP-0612516-SD	. . . Washer	1	29	B-2513-232-000	Feed plate carrier bar slide block	1
14	B-2520-232-000	Work clamp frame	1	30	SD-0850751-SP	. . . Hinge screw	1
15	B-2521-232-000	Work clamp hook	2	31	B-2545-232-000	Feed plate carrier bar slide plate	1
16	B-2543-232-000	Feed across driving block	1				
17	B-2544-232-000	Feed across driving block pin	1				

9. FEED ACROSS SHAFT COMPONENTS

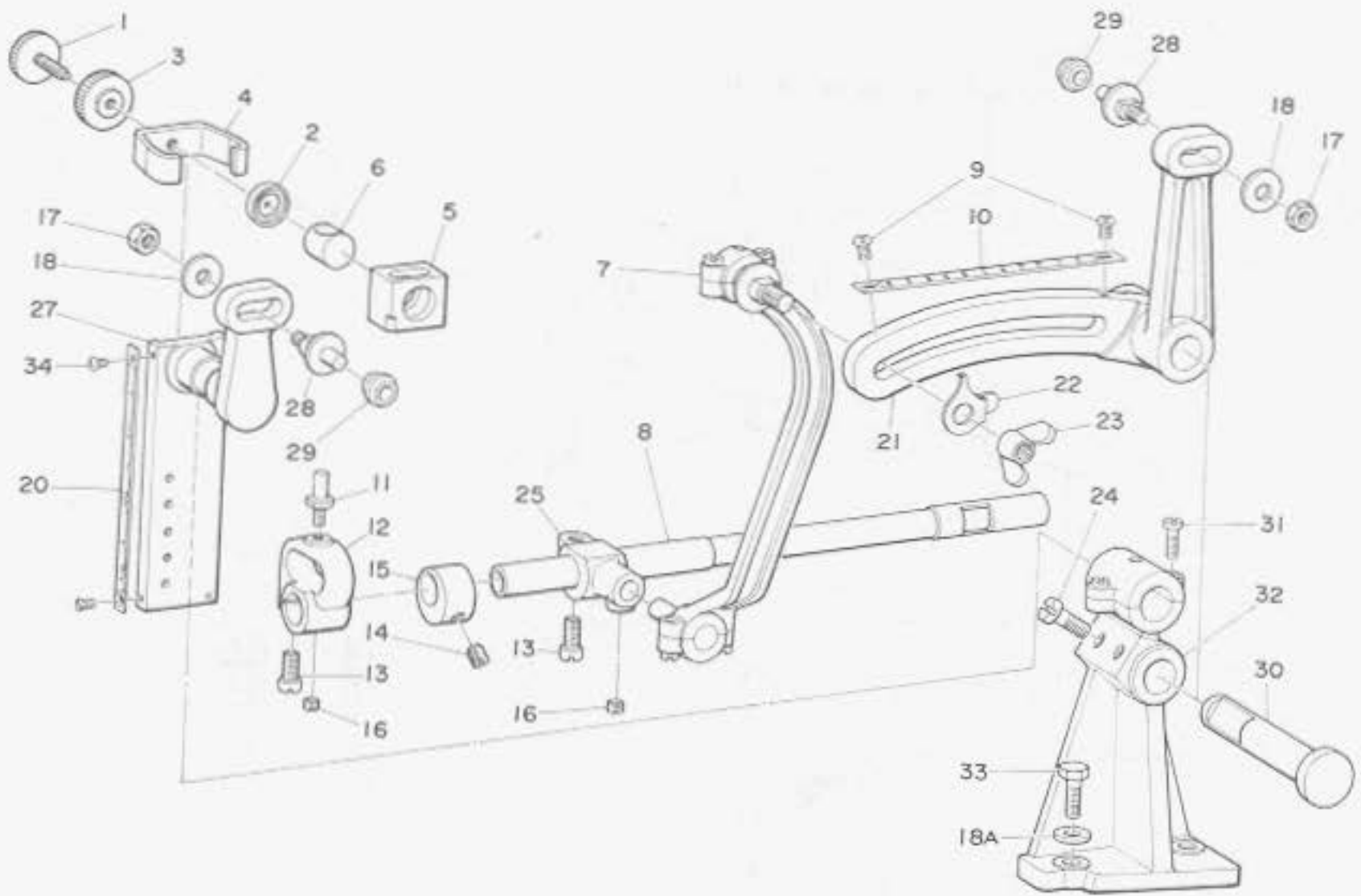

Ref. No.	Part No.	Description	Amt. Req.	Ref. No.	Part No.	Description	Amt. Req.
1	B-2510-232-000	Thumb screw, for swivel clamp	1	17	NS-6150430-SP	Nut, for roller stud	2
2	B-2511-232-000	Swivel clamp circle clip	1	18	WP-0621016-SD	Washer, for roller stud & bearing	2
3	B-2518-232-000	Lock nut, for swivel clamp	1	20	B-2516-232-000	Feed scale	1
4	B-2508-232-000	Feed regulator swivel clamp	1	21	B-2528-232-000	Feed across regulator	1
5	B-2506-232-000	Feed regulator swivel	1	22	B-2531-232-000	Pointer	1
6	B-2507-232-000	. . . Hinge stud	1	23	B-2528-280-000	Wing nut	1
7	B-2534-232-0A0	Ball joint connection complete	1	24	SS-6151780-SP	Clamp screw, for feed across	2
8	B-2536-232-000	Feed across shaft	1	25	B-2539-232-000	Feed across shaft crank, rear	1
9	SS-3090610-SP	Clamp screw, for feed across scale	2	27	B-2501-232-000	Feed regulator	1
10	B-2526-232-000	Feed across scale	1	28	B-2503-232-000	Roller stud	2
11	B-2542-232-000	Driving stud, for feed across shaft crank, front	1	29	B-2502-232-000	Roller	2
12	B-2541-232-000	Feed across shaft crank, front	1	30	B-2529-232-000	Feed across regulator shaft	1
13	SS-7151210-SP	Clamp screw, for feed across shaft crank	2	32	B-2527-232-000	Bearing bracket	1
15	B-2537-232-0A0	Feed across shaft set collar	1	31	SS-7111110-TP	Clamp screw, for feed regulator	2
14	SS-8150710-SP	Clamp screw, for set collar & rear crank	3	33	SS-9151630-CP	. . . Clamp screw	2
16	SS-8150410-TP	Clamp screw, for feed across shaft crank	2	18A	WP-0621016-SD	Washer, for bearing bracket	2
				34	SS-3060410-SP	Screw, for feed scale	2

10. STOP MOTION LEVER COMPONENTS

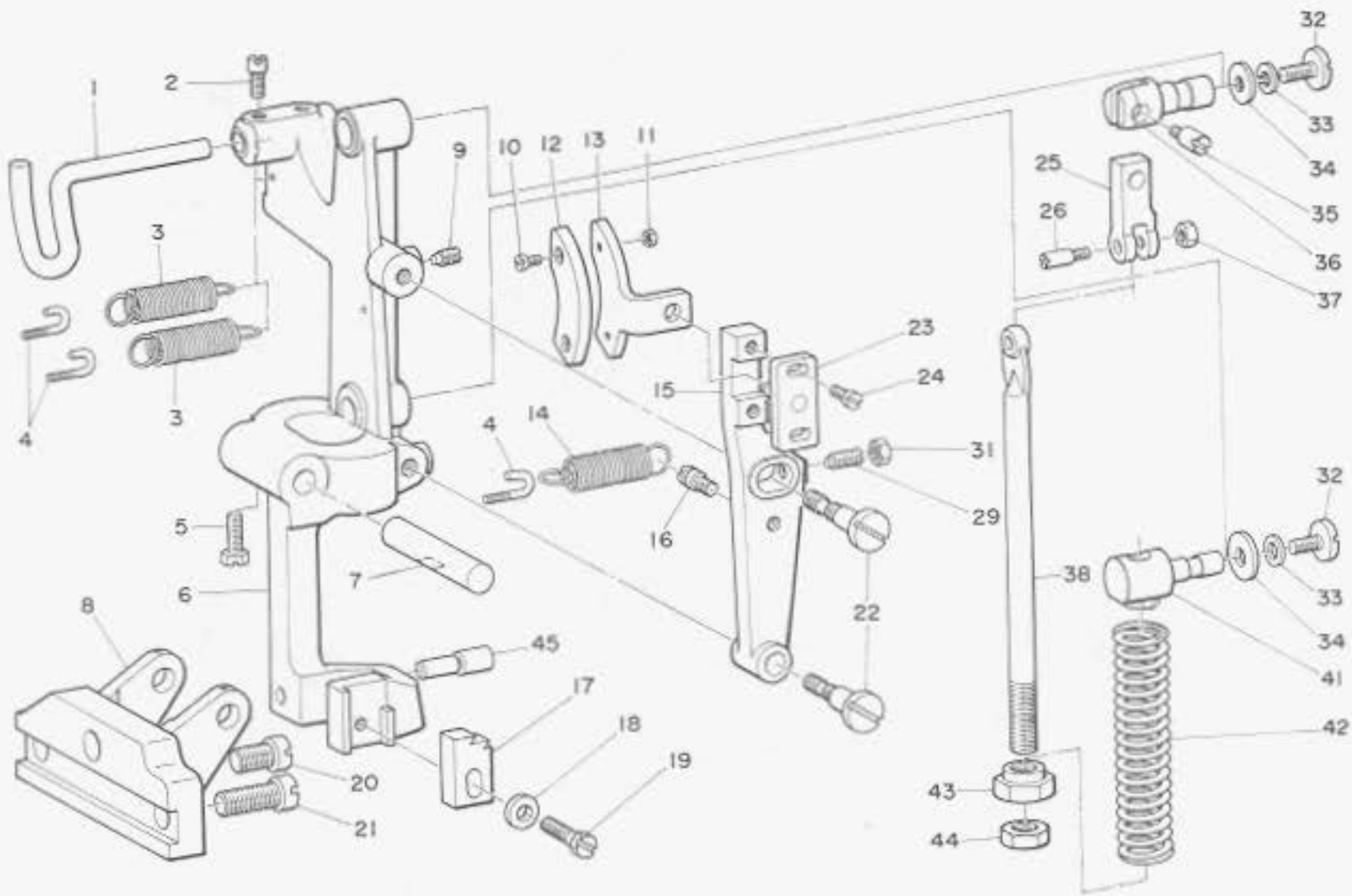

Ref. No.	Part No.	Description	Amt. Req.	Ref. No.	Part No.	Description	Amt. Req.
1	B-2605-232-000	Belt shifter	1	22	B-2655-232-000	Brake lever hinge pin	2
2	SS-7151120-SP	. . . Clamp screw	2	23	B-2658-232-0A0	Brake regulating bracket complete	1
3	B-2632-232-000	Tension spring, for stop motion lever	2	24	SS-7111120-SP	. . . Clamp screw	2
4	B-2633-232-000	. . . Suspension screw	3	25	B-2607-232-000	Stop link	1
5	SS-9151630-CP	Clamp screw, for hinge stud	1	26	B-2613-232-000	. . . Hinge screw	1
6	B-2604-232-000	Stop motion lever	1	29	SS-8151550-SP	Set screw, for brake lever	1
7	B-2602-232-000	Stop motion lever hinge stud, with oil wick	1	31	NS-6150310-SP	Nut, for brake lever set screw	1
8	B-2601-232-000	Stop motion lever bearing bracket	1	32	SS-7151330-SP	End screw, for hinge stud	2
9	SS-8151150-SP	Clamp screw, for brake lever hinge pin	2	33	B-2623-232-000	. . . Washer	2
10	SS-7090910-SP	Clamp screw, for brake lining	2	34	WP-0612056-SD	. . . Thrust washer	2
11	NS-6090310-SP	. . . Nut	2	35	B-2611-232-000	Connecting screw, for stop link	1
12	B-2662-232-000	Brake lining	1	36	B-2608-232-000	Stop link hinge stud	1
13	B-2661-232-000	Brake block	1	37	NS-6620310-SP	Nut, for stop link hinge screw	1
14	B-2656-232-000	Tension spring, for brake	1	38	B-2612-232-000	Stop link rod	1
15	B-2651-232-000	Brake lever	1	41	B-2618-232-000	Stop link rod hinge stud	1
16	B-2657-232-000	Spring suspension screw	1	42	B-2619-232-000	Pressure spring, for stop link rod	1
17	B-2606-232-000	Stop motion lever catch	1	43	B-2621-232-000	Nut, for stop link rod (upper)	1
18	WP-0612516-SD	. . . Washer	1	44	NS-6240630-SP	Nut, for stop link rod (lower)	1
19	SS-9152130-SP	. . . Clamp screw	1	45	B-2648-232-000	Stop pin, for starting lever	1
20	SS-6241640-SP	Clamp screw (B), for bearing bracket	1				
21	SS-6242540-SP	Clamp screw (A), for bearing bracket	2				

11. TRIPPING LEVER & STARTING LEVER COMPONENTS

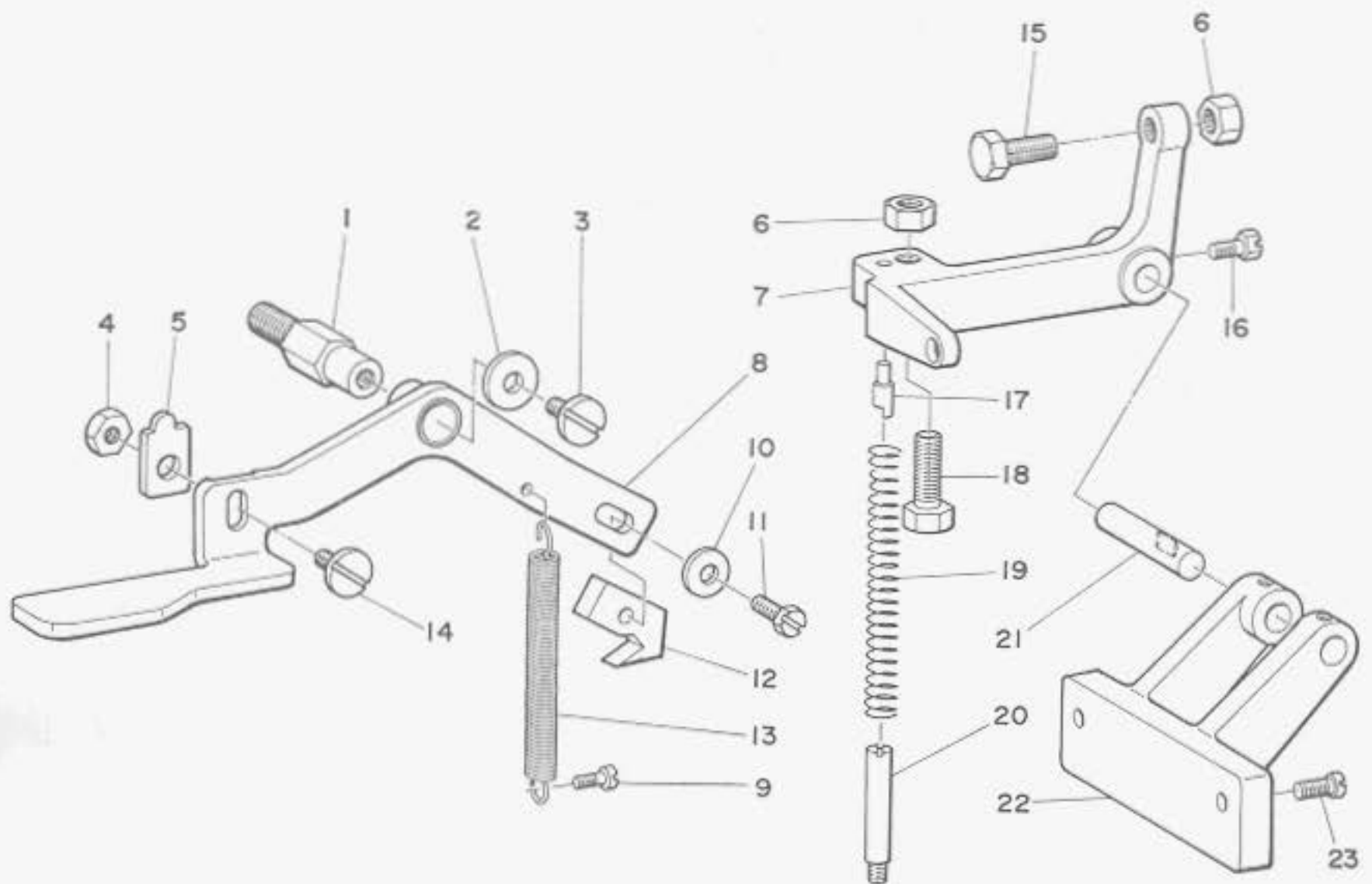

Ref. No.	Part No.	Description	Amt. Req.	Ref. No.	Part No.	Description	Amt. Req.
1	B-2640-232-000	Tripping lever hinge bolt	1	21	B-2659-232-000	Starting lever hinge stud	1
2	WP-0612056-SD	. . . Washer	2	22	B-2650-232-000	Starting lever bearing bracket	1
3	SS-7151330-SP	. . . Clamp screw	1	23	SS-7151210-SP	. . . Clamp screw	2
4	NS-6150440-SP	Nut, for tripping dog clamp screw	1				
5	B-2642-232-000	Tripping dog	1				
6	NS-6200710-SP	Nut, for starting lever set screw	2				
7	B-2646-232-000	Starting lever	1				
8	B-2639-232-0A0	Tripping lever complete	1				
9	SS-6111040-SP	Suspension screw, for tension spring	1				
10	WP-0612516-SD	Washer, for latch clamp screw	1				
11	SS-9151630-CP	Clamp screw, for latch	1				
12	B-2636-232-000	Latch	1				
13	B-2643-232-000	Tripping lever tension spring	1				
14	SS-7151330-SP	Clamp screw, for tripping dog	1				
15	SS-9202443-CP	Set screw (A), for starting lever	1				
16	SS-9151120-CP	Clamp screw, for starting lever	1				
17	B-2524-232-000	Positioning pin, for pressure spring guide screw	1				
18	SS-9202443-SP	Set screw (B), for starting lever	1				
19	B-2653-232-000	Starting lever pressure spring	1				
20	B-2654-232-000	. . . Guide screw	1				

12. EXCLUSIVE PARTS FOR LK-232-322 SUBCLASSES

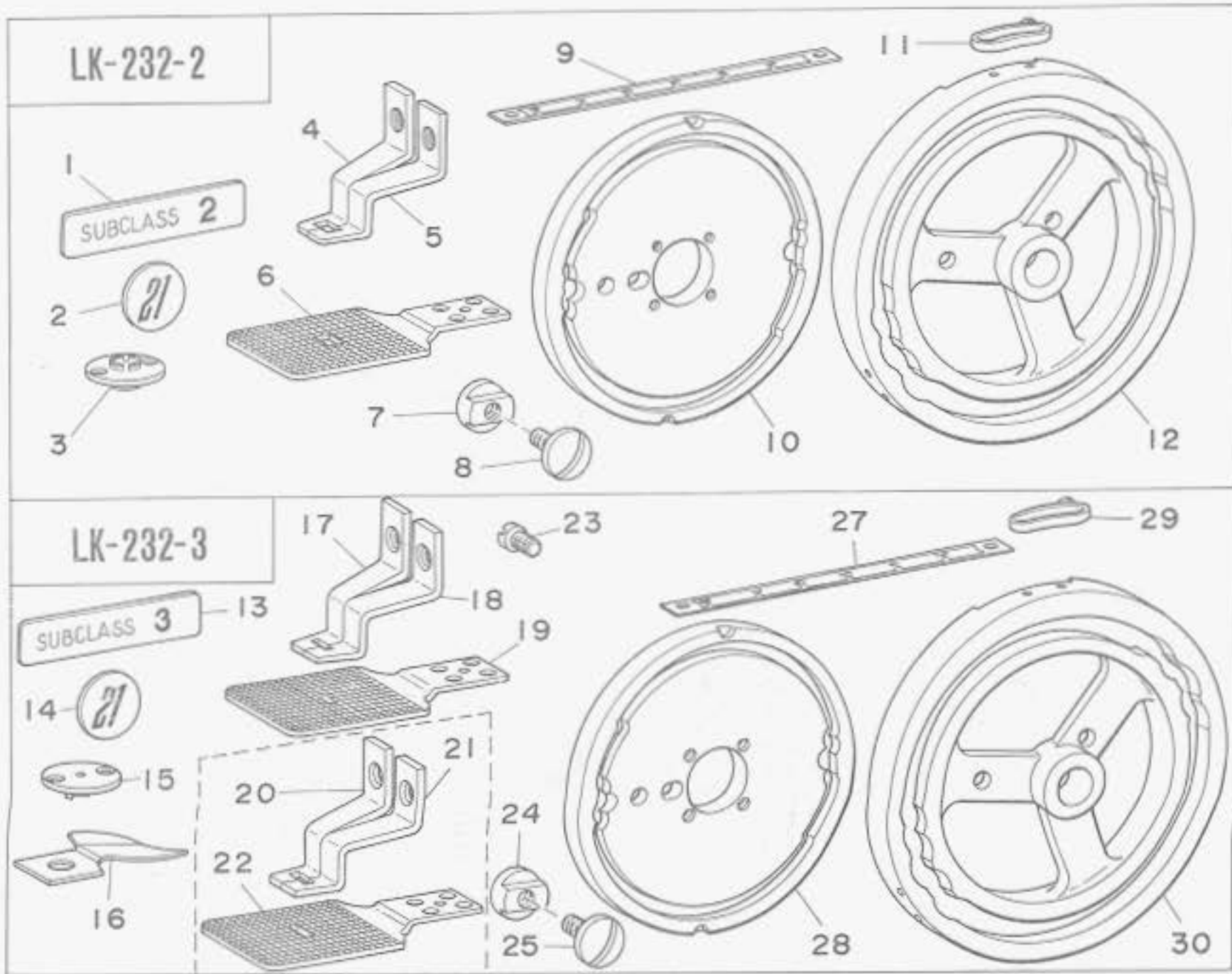

1) LK-232-2

Smaller bar tacking

Ref. No.	Part No.	Description	Amt. Req.
1	B-LKSUB00002	Subclass No. plate 2	1
2	D-1116-232-B00	Stitch number plate, for 21 stitches	1
3	D-2426-232-B00	Needle plate needle hole guide	1
*	D-2550-232-BA0	Work clamp foot complete	1
4	D-2551-232-B00	Work clamp foot, left	(1)
5	D-2550-232-B00	Work clamp foot, right	(1)
6	D-2517-232-B00	Feed plate	1
7	D-2530-232-B00	Feed across stop roller	1
8	SS-7151330-SP	. . . Screw	1
9	D-2526-232-B00	Feed across scale	1
10	D-2211-232-B00	Knife cam, for 21 stitches	1
11	D-2214-232-B00	Stop tripping segment (B), for 21 stitches	2
12	D-2209-232-B00	Feed cam, for 21 stitches	1

2) LK-232-3

Knit goods bar tacking

Ref. No.	Part No.	Description	Amt. Req.
13	B-LKSUB00003	Subclass No. plate 3	1
14	D-1116-232-B00	Stitch number plate, for 21 stitches	1

Ref. No.	Part No.	Description	Amt. Req.
15	D-2426-232-E00	Needle plate needle hole guide	1
16	D-2423-232-C00	Needle thread knife	1
*	D-2550-232-CA0	Work clamp foot complete	1
17	D-2551-232-C00	Work clamp foot, left	(1)
18	D-2550-232-C00	Work clamp foot, right	(1)
19	D-2517-232-C00	Feed plate	1
(20)	D-2551-232-C0A	Work clamp foot, left, large	(1)
(21)	D-2550-232-C0A	Work clamp foot, right, large	(1)
(22)	D-2517-232-C0A	Feed plate, large	(1)
23	SS-6090440-SP	Feed regulator stop screw	1
24	D-2530-232-B00	Feed across stop roller	1
25	SS-7151330-SP	. . . Screw	1
27	D-2526-232-B00	Feed across scale	1
28	D-2211-232-B00	Needle thread knife, for 21 stitches	1
29	D-2214-232-B00	Stop tripping segment (B), for 21 stitches	2
30	D-2209-232-B00	Feed cam, for 21 stitches	1

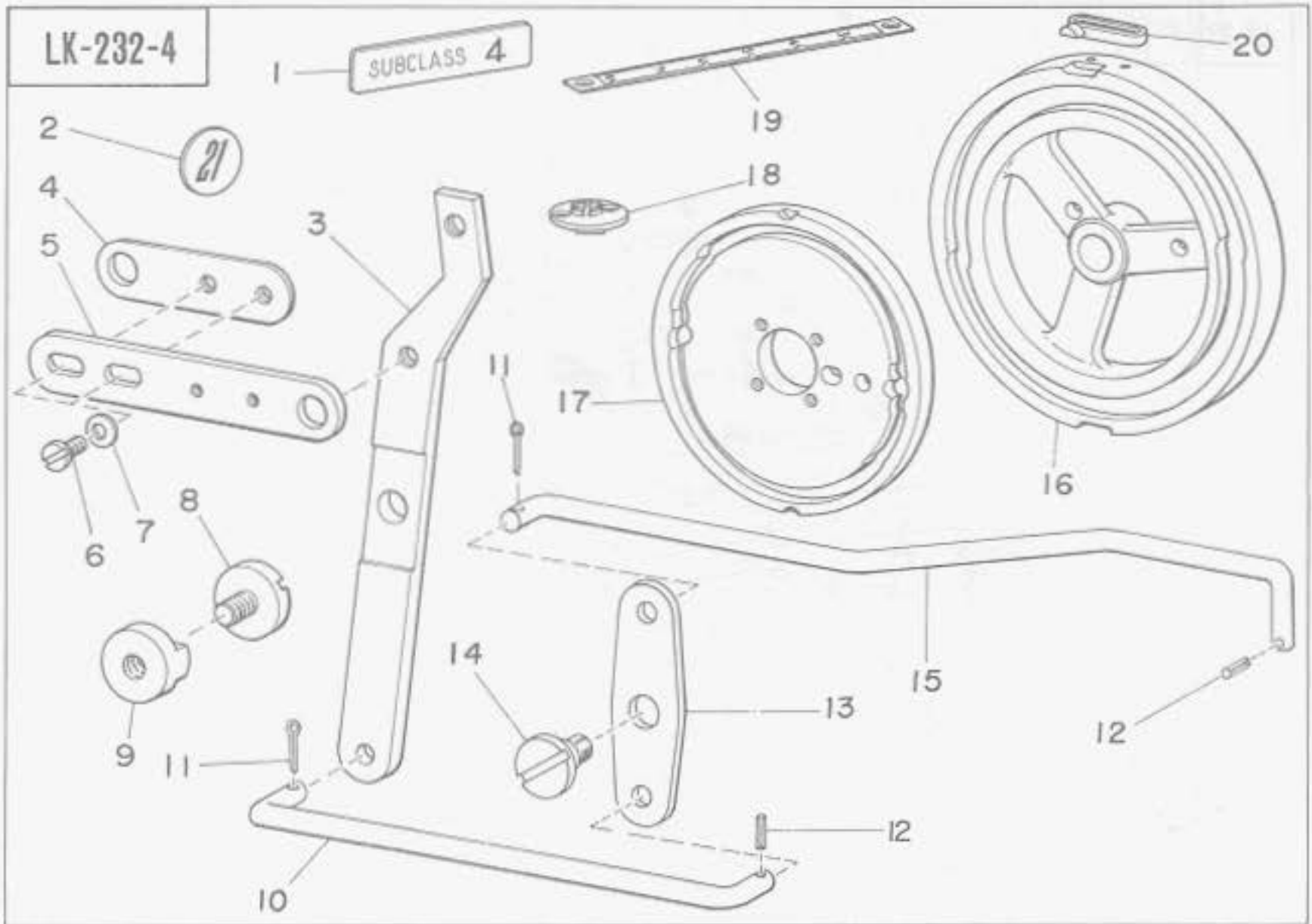

3) LK-232-4 (1) Tail of eyelet buttonhole bar tacking

Ref. No.	Part No.	Description	Amt. Req.	Ref. No.	Part No.	Description	Amt. Req.
1	B-LKSUB00004	Subclass No. plate 4	1	12	PS-0200082-K0	Spring pin	2
2	D-1116-232-800	Stitch number plate, for 21 stitches	1	13	D-2549-232-D00	Work clamp feet drive lever connecting lever	1
3	D-1519-232-D00	Lifting lever stop bracket	1	14	SD-0790303-SP	Hinge screw	1
4	D-1523-232-D00	Lifting lever link (B)	1	15	D-2547-232-D00	Work clamp feet drive lever connecting rod	1
5	D-1522-232-D00	Lifting lever link (A)	1	16	D-2209-232-800	Feed cam, for 21 stitches	1
6	SS-7110710-SP	Screw	2	17	D-2211-232-800	Knife cam, for 21 stitches	1
7	WP-0480856-SP	Washer	2	18	D-2426-232-E00	Needle plate needle hole guide	1
8	SS-7151330-SP	Stop screw, for roller	1	19	D-2526-232-800	Feed across scale	1
9	D-2530-232-800	Feed across stop roller	1	20	D-2214-232-800	Stop tripping segment (B), for 21 stitches	2
10	D-2546-232-D00	Work clamp feet drive lever connecting rod (A)	1				
11	PD-0201000-08	Cotter pin	2				

LK-232-4

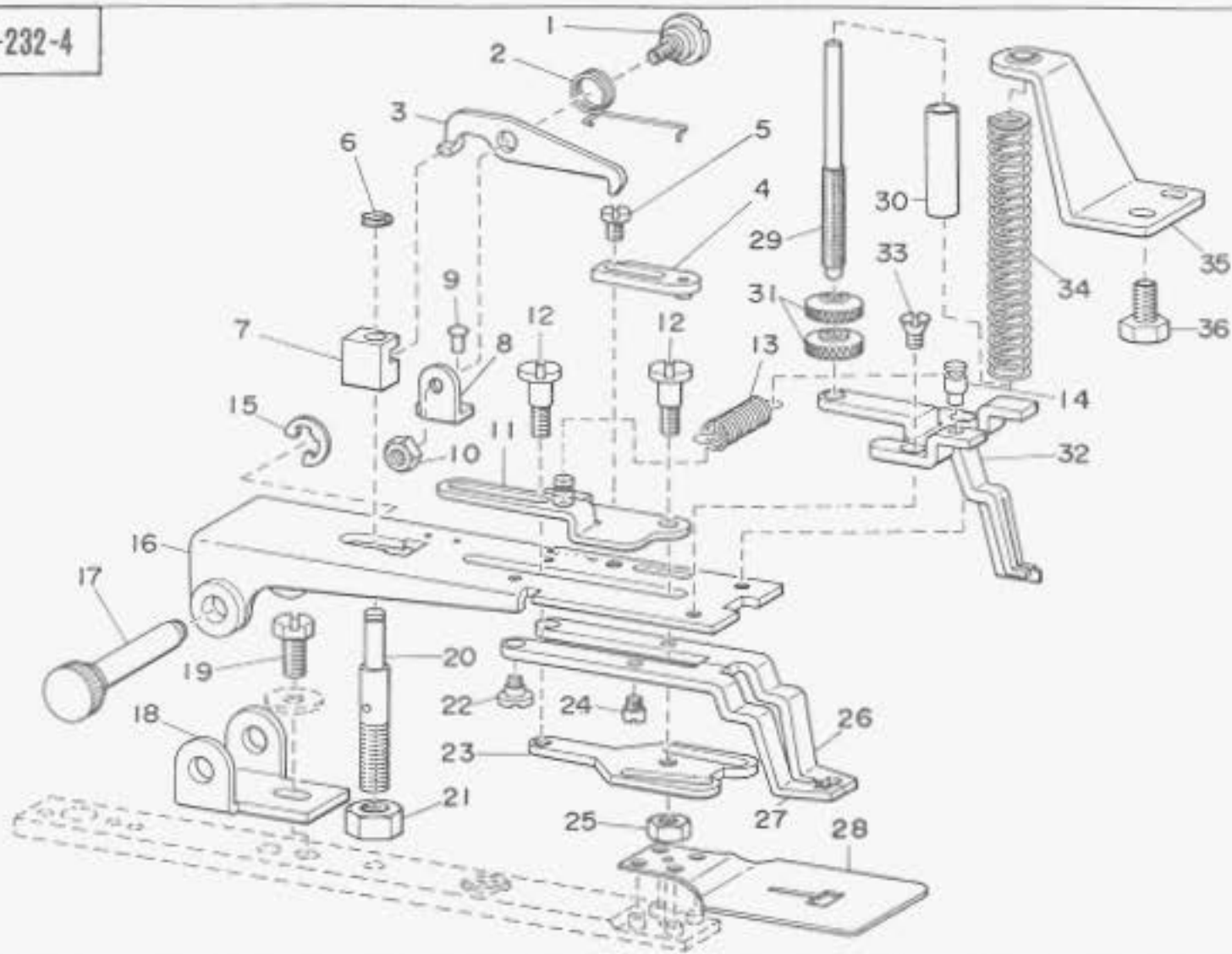

3) LK-232-4 (2)

Ref. No.	Part No.	Description	Amt. Req.	Ref. No.	Part No.	Description	Amt. Req.
1	D-2511-232-D00	Screw	1	18	D-2501-232-D00	Base	1
2	D-2512-232-D00	Torsion spring	1	19	SS-9151160-CP	Screw	1
3	D-2509-232-D00	Work clamp feet drive lever stationing latch	1	20	D-2506-232-D00	Stationing block shaft	1
4	D-2516-232-DA0	Work clamp feet regulator asm.	1	21	NS-6200710-SP	Nut	1
5	SS-9110543-SP	Screw	1	22	SD-0550271-TP	Hinge screw, for work clamp feet	2
6	D-2548-232-D00	Snap ring, for connecting rod	1	23	D-2519-232-D00	Work clamp feet plate cam	1
7	D-2507-232-D00	Stationing block	1	24	D-2522-232-D00	Pin	2
8	D-2510-232-D00	Stationing latch bearing bracket	1	25	NS-6120480-SP	Nut, for guide hinge screw	2
9	D-2580-232-D00	Knock pin	2	26	D-2521-232-DA0	Work clamp foot, right	1
10	NS-6110530-SP	Nut	1	27	D-2520-232-DA0	Work clamp foot, left	1
11	D-2513-232-DA0	Work clamp feet bearing bracket guide asm.	1	28	D-2517-232-D00A	Feed plate	1
12	D-2545-232-D0A	Hinge screw	2	29	D-2528-232-D00	Pressure spring regulating shaft	1
13	D-2515-232-D00	Torsion spring	1	30	D-2527-232-D00	Sleeve	1
14	D-2514-232-D00	Pin	1	31	B-3117-352-000	Regulating nut	2
15	RE-0700000-K0	Snap ring	1	32	D-2505-282-AA0	Work clamp foot guide jaw	1
16	D-2504-232-DA0	Work clamp feet bearing bracket assembly	1	33	SS-1110640-SP	Screw	2
17	D-2502-232-D00	Shaft block shaft	1	34	D-2529-232-D00	Pressure spring	1
				35	D-2525-232-D00	Retaining plate	1
				36	SS-9150730-SP	Screw	2

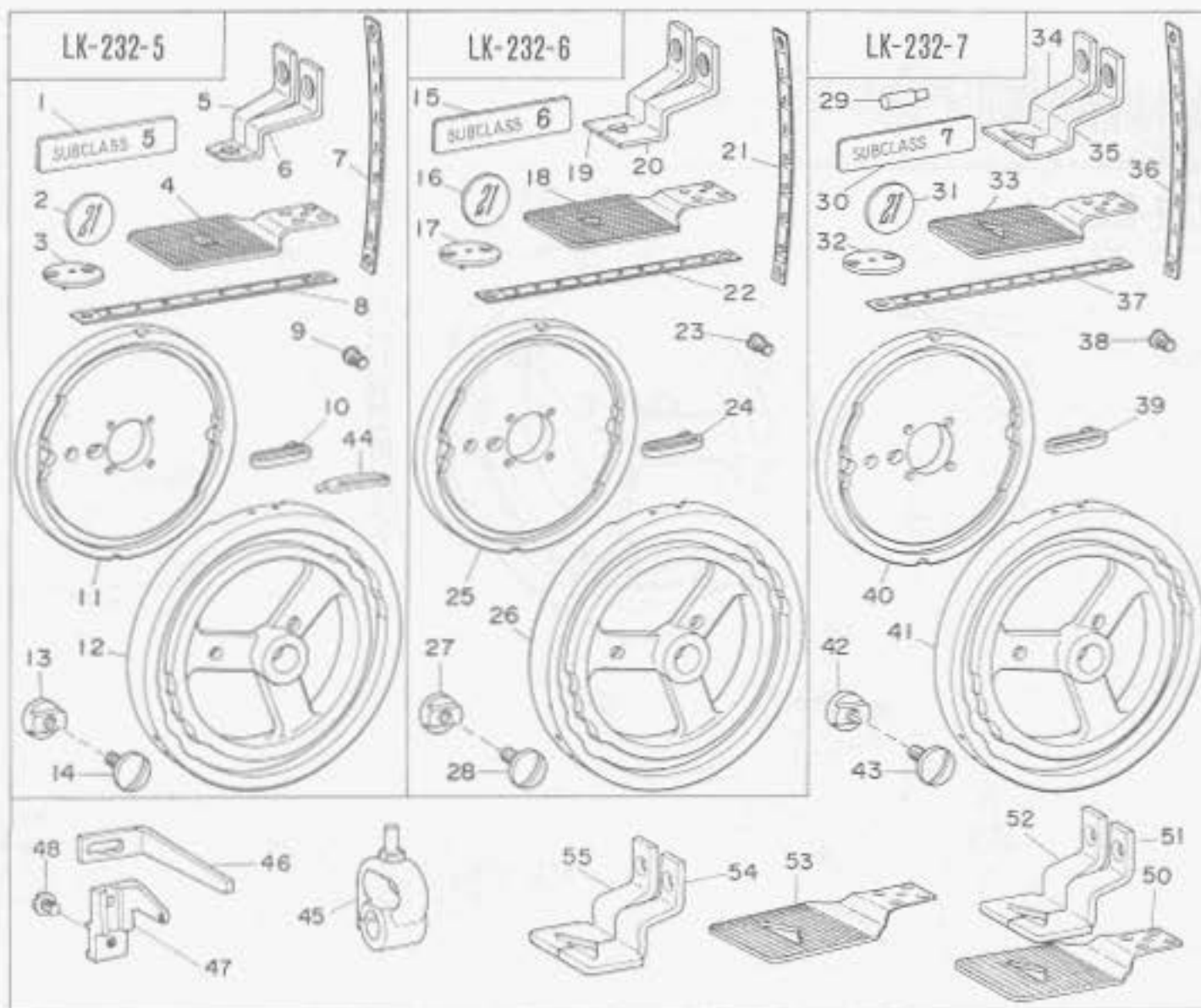

4) LK-232-5 Inverted pentagonal shaping

Ref. No.	Part No.	Description	Amt. Req.
1	B-LKSUB00005	Subclass No. plate 5	1
2	D-1116-232-B00	Stitch number plate, for 21 stitches	1
3	D-2426-232-E00	Needle plate needle hole guide, for special tacks	1
4	D-2517-232-E00	Feed plate, for inverted pentagon	1
*	D-2550-232-EA0	Work clamp foot complete	1
5	D-2551-232-E00	Work clamp foot, left, for inverted pentagon	(1)
6	D-2550-232-E00	Work clamp foot, right for inverted pentagon	(1)
7	D-2516-232-E00	Feed scale, for inverted pentagon	1
8	D-2526-232-E00	Feed across scale, for inverted pentagon	1
9	SS-6090440-SP	Feed regulator stop screw	1
10	D-2214-232-B00	Stop tripping segment (B), for 21 stitches	2
11	D-2211-232-B00	Knife cam, for 21 stitches	1
12	D-2209-232-E00	Feed cam, for inverted pentagon 21 stitches	1
13	D-2530-232-B00	Feed across stop roller	1
14	SS-7151330-SP	... Screw	1
44	D-2220-232-K00	Thread nipper tripping segment	2

5) LK-232-6 Right sided triangle shaping

15	B-LKSUB00006	Subclass No. plate 6	1
16	D-1116-232-B00	Stitch number plate, for 21 stitches	1
17	D-2426-232-E00	Needle plate needle hole guide, for special tacks	1
18	D-2517-232-F00	Feed plate, for right sided triangle	1
*	D-2550-232-FA0	Work clamp foot complete	1
19	D-2551-232-F00	Work clamp foot, left, for right sided triangle	(1)
20	D-2550-232-F00	Work clamp foot, right, for right sided triangle	(1)
21	D-2516-232-E00	Feed scale	1
22	D-2526-232-F00	Feed across scale	1
23	SS-6090440-SP	Feed regulator stop screw	1
24	D-2214-232-B00	Stop tripping segment (B), for 21 stitches	2

Ref. No.	Part No.	Description	Amt. Req.
25	D-2211-232-B00	Knife cam, for 21 stitches	1
26	D-2209-232-F00	Feed cam	1
27	D-2530-232-B00	Feed across stop roller	1
28	SS-7151330-SP	... Screw	1

6) LK-232-7 Triangle shaping

29	D-2524-232-M00	Work clamp foot bracket positioning pin	2
30	B-LKSUB00007	Subclass No. plate 7	1
31	D-1116-232-B00	Stitch number plate, for 21 stitches	1
32	D-2426-K9S-E00	Needle plate needle hole guide for special tacks	1
33	D-2517-232-G00	Feed plate, for standard size line materials	1
*	D-2550-232-GA0	Work clamp foot complete	1
34	D-2551-232-G00	Work clamp foot, left	1
35	D-2550-232-G00	Work clamp foot, right	1
36	D-2516-232-L00	Feed scale (same as H-shaped)	1
37	D-2526-232-G00	Feed across scale	1
38	SS-6090440-SP	Feed regulator stop screw	1
39	D-2214-232-B00	Stop tripping segment (B), for 21 stitches	2
40	D-2211-232-B00	Knife cam, for 21 stitches	1
41	D-2209-232-G00	Feed cam	1
42	D-2530-232-B00	Feed across stop roller	1
43	SS-7151330-SP	... Screw	1
45	D-2541-232-GA0	Feed across shaft crank, front, asm.	1
46	B-1501-232-00B	Clamp foot lifting lever	1
47	B-1503-232-00B	... Base	1
48	SS-7110820-SP	... Screw	1
50	D-2517-232-G0B	Feed plate (B), for standard size heavy weight materials	1
51	D-2550-232-G0B	Work clamp foot (right)	1
52	D-2551-232-G0B	Work clamp foot (left)	1
53	D-2517-232-G0C	Feed plate (C), for maximum size heavy weight materials	1
54	D-2550-232-G0C	Work clamp foot (right)	1
55	D-2551-232-G0C	Work clamp foot (left)	1

LK-232-8

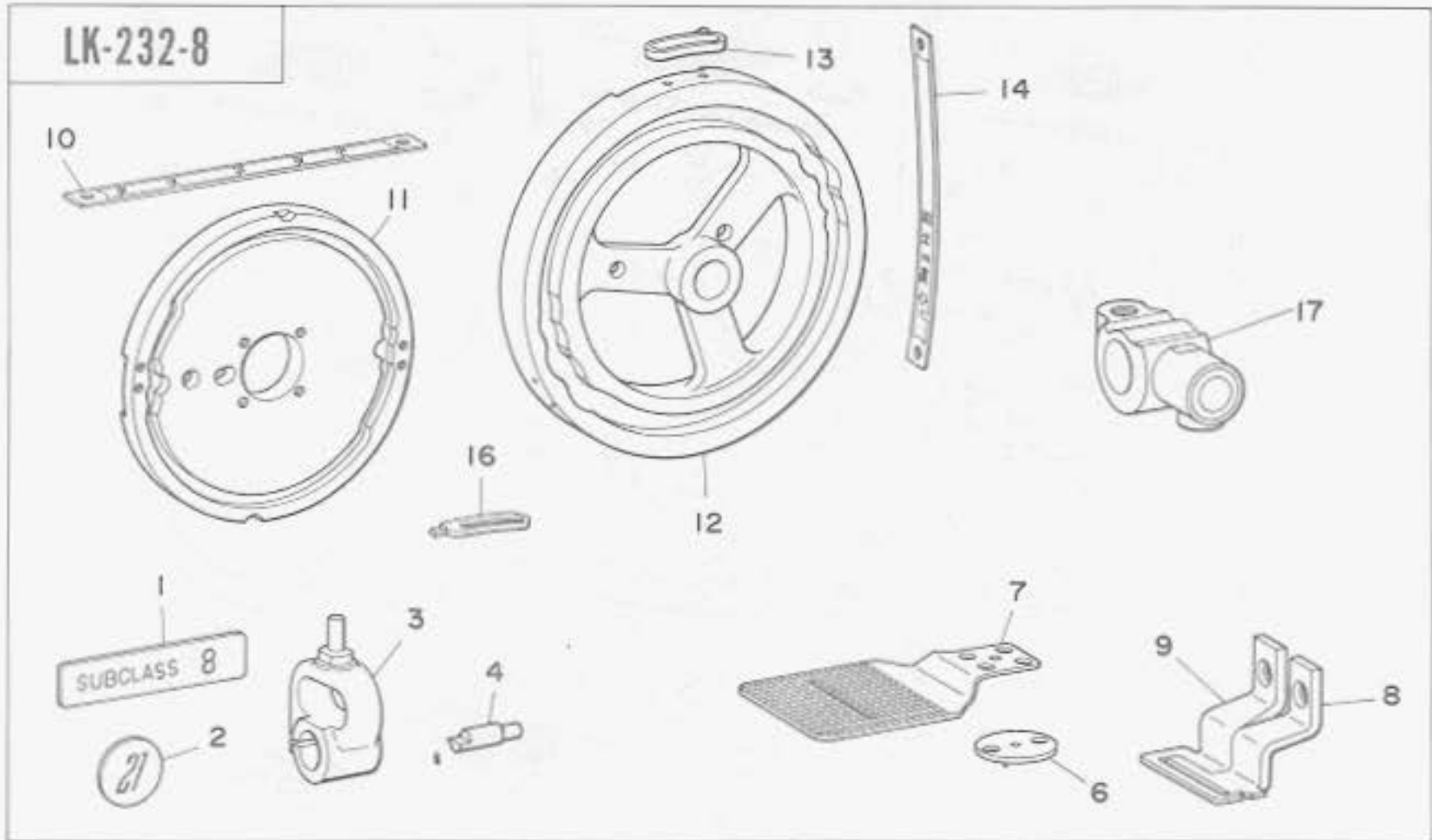

7) LK-232-8 LABEL ATTACHING MACHINE

Ref. No.	Part No.	Description	Amt. Req.
1	B-LKSUB00008	Subclass No. plate 8	1
2	D-1116-232-800	Stitch number plate, for 21 stitches	1
3	D-2541-K0R-TA0	Feed across shaft crank, front B asm.	1
4	D-2424-K7R-Y00	Positioning pin, for work clamp foot bracket	2
6	D-2426-232-E00	Needle plate needle hole guide	1
7	D-2517-232-H00	Feed plate	1
*	D-2550-232-HA0	Work clamp foot, left & right asm.	1
8	D-2550-232-H00	Work clamp foot, right	(1)
9	D-2551-232-H00	Work clamp foot, left	(1)
10	D-2526-232-H00	Feed scale	1
11	D-2211-232-B00	Knife cam, for 21 stitches	1
12	D-2209-232-H00	Feed cam	1
13	D-2214-232-B00	Stop tripping segment (B), for 21 stitches	2
14	D-2516-232-H00	Feed across scale	1
16	D-2220-232-K00	Thread nipper tripping segment	1
17	D-2539-K7R-W00	Feed across shaft crank, rear	1
○	All parts not mentioned above are same as those of model LK-232.		

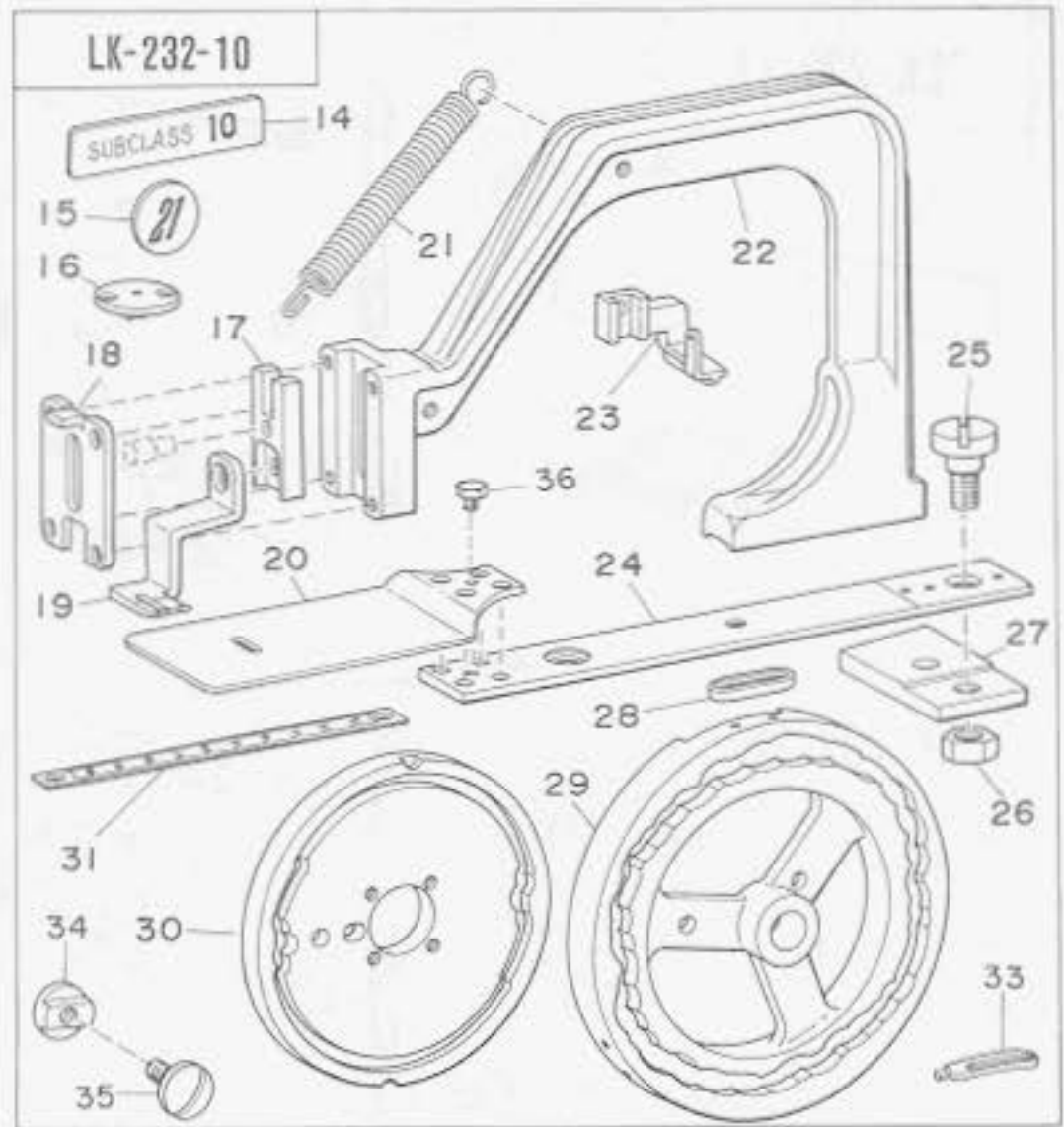
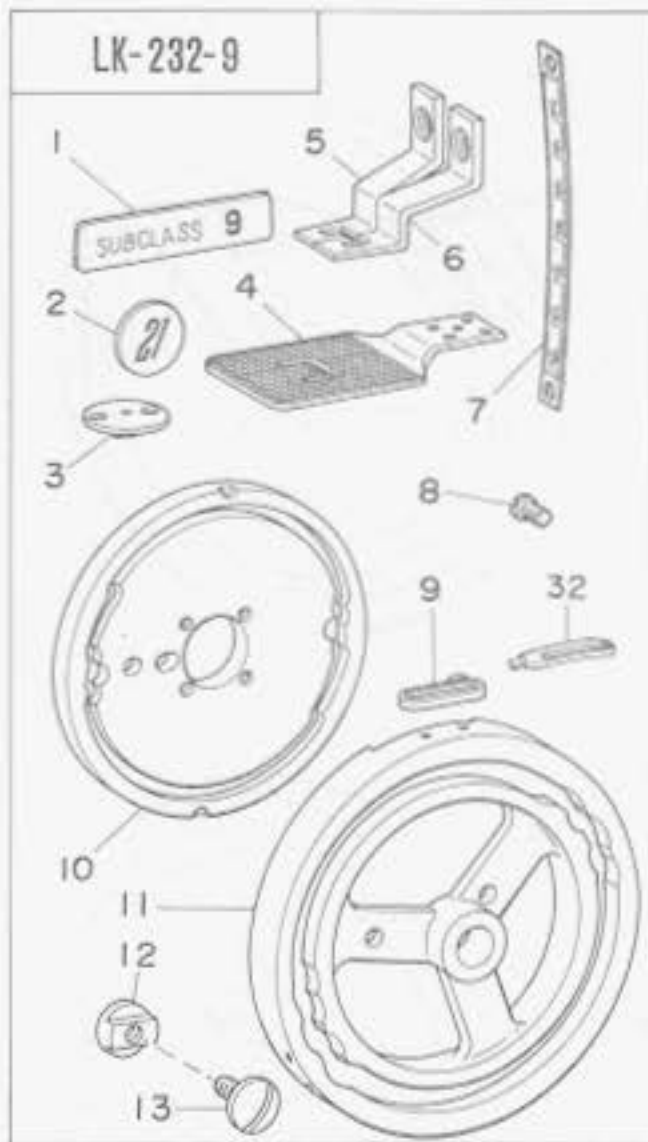

8) LK-232-9

Gate shaped bar tacking

Ref. No.	Part No.	Description	Amt. Req.
1	B-LKSUB00009	Subclass No. plate 9	1
2	D-1116-232-800	Stitch number plate, for 21 stitches	1
3	D-2426-232-E00	Needle plate needle hole guide, for special tacks	1
4	D-2517-232-J00	Feed plate	1
5	D-2550-232-JA0	Work clamp foot complete	1
6	D-2551-232-J00	Work clamp foot, left	(1)
7	D-2550-232-J00	Work clamp foot, right	(1)
8	D-2516-232-E00	Feed scale	1
9	SS-6090440-SP	Feed regulator stop screw	1
10	D-2214-232-800	Stop tripping segment (B), for 21 stitches	2
11	D-2211-232-800	Knife cam, for 21 stitches	1
12	D-2209-232-J00	Feed cam	1
13	D-2530-232-B00	Feed across stop roller	1
32	SS-7151330-SP	Thread nipper tripping segment	2

9) LK-232-10

Band loop attaching tacks

Ref. No.	Part No.	Description	Amt. Req.
14	B-LKSUB00010	Subclass No. plate 10	1
15	D-1116-232-800	Stitch number plate, for 21 stitches	1
16	D-2426-232-E00	Needle plate needle hole guide, for special tacks	1
17	D-2523-232-K00	Work clamp bracket	1

Ref. No.	Part No.	Description	Amt. Req.
18	D-2525-232-K00	Work clamp face plate	1
19	D-2550-232-K00	Work clamp foot	1
20	D-2517-232-K00	Feed plate	1
21	D-2546-232-K00	Pressure spring	1
22	D-2520-232-K00	Work clamp frame	1
23	D-1501-232-K00	Clamp foot lifting lever	1
24	D-2512-232-K00	Feed plate carrier bar	1
25	SD-0950491-SP	... Hinge screw	1
26	NS-6660430-SP	... Nut	1
27	D-2519-232-K00	... Guide plate	1
28	D-2214-232-800	Stop tripping segment (B), for 21 stitches	2
29	D-2209-232-K00	Feed cam	1
30	D-2211-232-800	Knife cam, for 21 stitches	1
31	D-2526-232-F00	Feed across scale	1
33	D-2220-232-K00	Thread nipper tripping segment	2
34	D-2530-232-B00	Feed across stop roller	1
35	SS-7151330-SP	... Screw	1
36	SS-9110543-CP	Screw, for feed plate	1

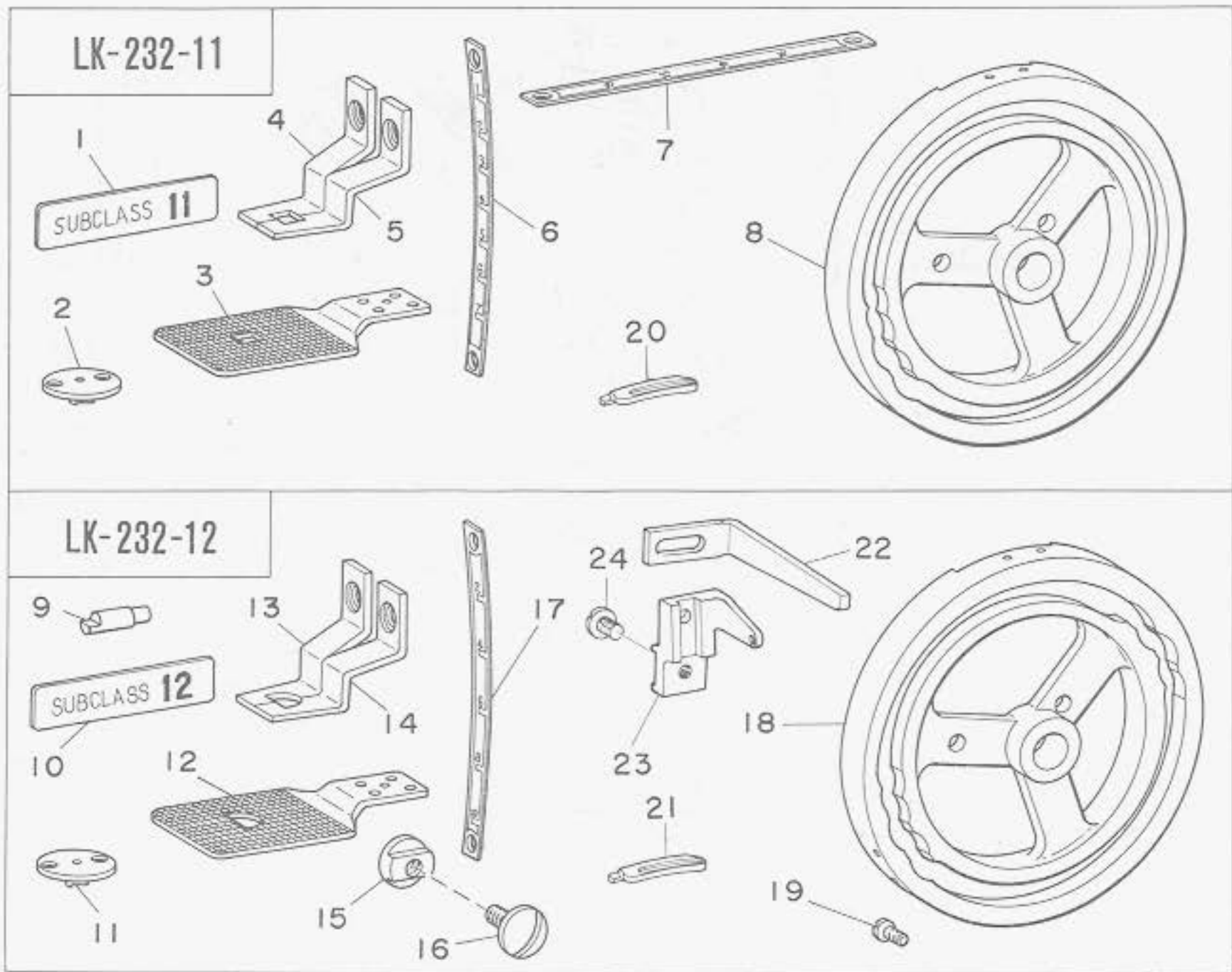

Ref. No.	Part No.	Description	Amt. Req.	Ref. No.	Part No.	Description	Amt. Req.
10)	LK-232-11	H-shaped bar tacking					
1	B-LKSUB00011	Subclass No. plate 11	1	12	D-2517-232-M00	Feed plate	1
2	D-2426-232-E00	Needle plate needle hole guide, for special tacks	1	*	D-2550-232-MA0	Work clamp foot complete	1
3	D-2517-232-L00	Feed plate	1	13	D-2551-232-M00	Work clamp foot, left	(1)
*	D-2550-232-LA0	Work clamp foot complete	1	14	D-2550-232-M00	Work clamp foot, right	(1)
4	D-2551-232-L00	Work clamp foot, left	(1)	15	D-2530-232-B00	Feed across stop roller	1
5	D-2550-232-L00	Work clamp foot, right	(1)	16	SS-7151330-SP	. . . Screw	1
6	D-2516-232-L00	Feed scale 1	1	17	D-2516-232-M00	Feed scale	1
7	D-2526-232-L00	Feed across scale	1	18	D-2209-232-M00	Feed cam	1
8	D-2209-232-L00	Feed cam	1	19	SS-6090440-SP	Feed regulator stop screw	1
20	D-2220-232-K00	Thread nipper tripping segment	1	21	D-2220-232-K00	Thread nipper tripping segment	1
				22	B-1501-232-00B	Clamp foot lifting lever	1
				23	B-1503-232-00B	. . . Base	1
				24	SS-7110820-SP	. . . Screw	1
11)	LK-232-12	Semi-circular shape bar tacking					
9	D-2524-K7R-Y00	Work clamp foot bracket positioning pin	2				
10	B-LKSUB00012	Subclass number plate 12	1				
11	D-2426-232-E00	Needle plate needle hole guide, for special tacks	1				

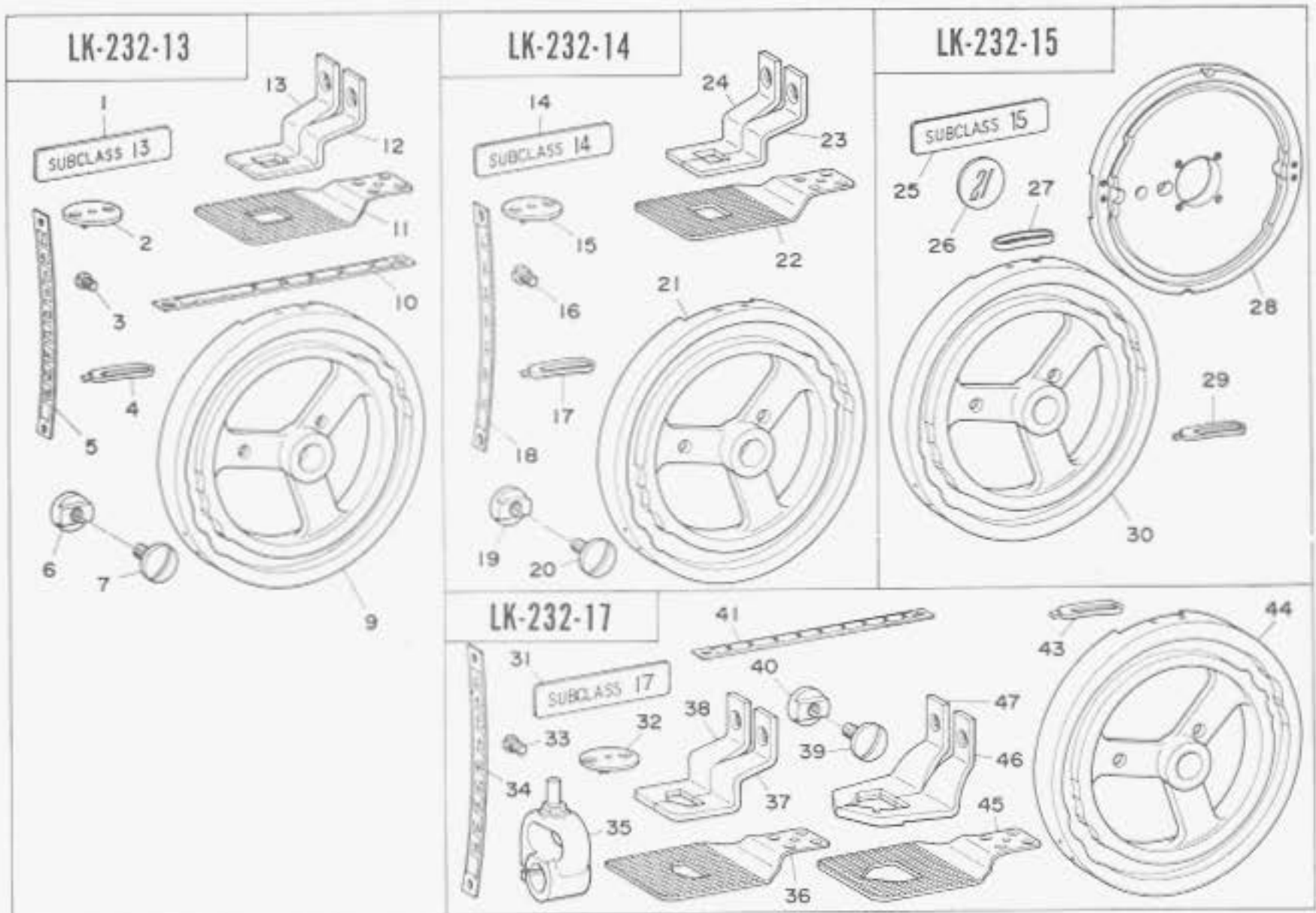

12) LK-232-13 SQUARE SHAPED TACKING MACHINE

14) LK-232-15 RECTANGLE SHAPING MACHINE

Ref. No.	Part No.	Description	Amt. Req.
1	B-LKSUB00013	Subclass No. plate 13	1
2	D-2426-232-E00	Needle plate needle hole guide	1
3	SS-6090440-SP	Feed regulator stop screw	1
4	D-2220-232-K00	Thread nipper tripping segment	1
5	D-2516-232-S00	Feed scale	1
6	D-2530-232-B00	Feed across stop roller	1
7	SS-7151330-SP	. . . Screw	1
9	D-2209-232-N00	Feed cam	1
10	D-2526-322-D00	Feed across scale	1
11	D-2517-232-N00	Feed plate	1
*	D-2550-232-NA0	Work clamp foot, right & left asm.	1
12	D-2550-232-N00	Work clamp foot, right	(1)
13	D-2551-232-N00	Work clamp foot, left	(1)
	D-2517-232-N0B	Feed plate, for large width	(1)
	D-2550-232-N0B	Work clamp foot, right, for wide width	(1)
	D-2551-232-N0B	Work clamp foot, left, for wide width	(1)
	D-2524-K7R-U00	Positioning pin, for work clamp foot bracket	(2)

Ref. No.	Part No.	Description	Amt. Req.
25	B-LKSUB00015	Subclass No. plate 15	1
26	D-1116-232-B00	Stitch number plate, for 21	1
27	D-2214-232-B00	Stop tripping segment B, for 21 stitches	2
28	D-2211-232-B00	Knife cam, for 21 stitches	1
29	D-2220-232-K00	Thread nipper tripping segment	2
30	D-2209-232-Q00	Feed cam	1

○ All parts not mentioned above are same as those of model LK-232.

15) LK-232-17 PENTAGONAL SHAPING MACHINE

Ref. No.	Part No.	Description	Amt. Req.
31	B-LKSUB00017	Subclass No. plate 17	1
32	D-2426-232-E00	Needle plate needle hole guide	1
33	SS-6090440-SP	Feed regulator stop screw	1
34	D-2516-232-S00	Feed scale	1
35	D-2541-232-GA0	Feed across shaft crank, front B asm.	1
36	D-2517-232-S00	Feed plate	1
*	D-2550-232-SA0	Work clamp foot, right & left asm.	1
37	D-2550-232-S00	Work clamp foot, right	(1)
38	D-2551-232-S00	Work clamp foot, left	(1)
39	SS-7151330-SP	Feed across stop roller set screw	1
40	D-2530-232-B00	Feed across stop roller	1
42	D-2545-232-N00	Slide plate, for feed plate carrier bar	1
43	D-2220-232-K00	Thread nipper tripping segment	1
44	D-2209-232-S00	Feed cam	1
(45)	D-2517-232-S0B	Feed plate, for heavy weight materials	(1)
(46)	D-2550-232-S0B	Work clamp foot, right for heavy weight materials	(1)
(47)	D-2551-232-S0B	Work clamp foot, left for heavy weight materials	(1)

○ All parts not mentioned above are same as those of model LK-232.

13) LK-232-14 ZIGZAG SHAPED TACKING MACHINE

Ref. No.	Part No.	Description	Amt. Req.
14	B-LKSUB00014	Subclass No. plate 14	1
15	D-2426-232-E00	Needle plate needle hole guide	1
16	SS-6090440-SP	Feed regulator stop screw	1
17	D-2220-232-K00	Thread nipper tripping segment	1
18	D-2516-232-M00	Feed scale	1
19	D-2530-232-B00	Feed across stop roller	1
20	SS-7151330-SP	. . . Screw	1
21	D-2209-232-P00	Feed cam	1
22	D-2517-232-P00	Feed plate	1
*	D-2550-232-PA0	Work clamp foot, right & left asm.	1
23	D-2550-232-P00	Work clamp foot, right	(1)
24	D-2551-232-P00	Work clamp foot, left	(1)

○ All parts not mentioned above are same as those of model LK-232.

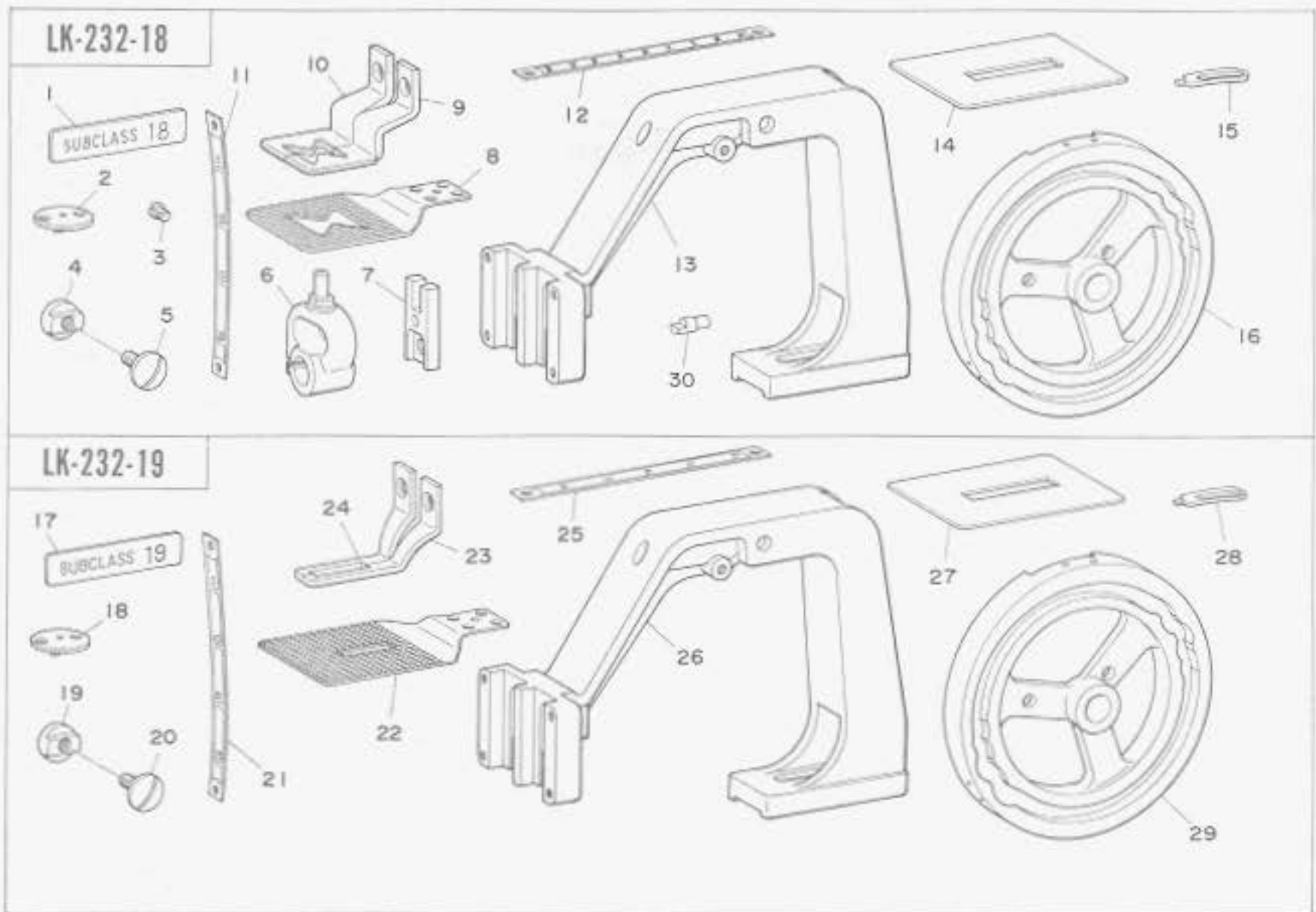

16) LK-232-18 X-SHAPED TACKING MACHINE MACHINE

Ref No.	Part No.	Description	Amt. Req.
1	B-LKSUB00018	Subclass No. plate 18	1
2	D-2426-232-E00	Needle plate needle hole guide	1
3	SS-6090440-SP	Feed regulator stop screw	1
4	D-2530-232-B00	Feed across stop roller	1
5	SS-7151330-SP	. . . Screw	1
6	D-2541-232-GA0	Feed across shaft crank, front B asm.	1
7	D-2523-232-K00	Work clamp bracket	1
8	D-2517-232-T00	Feed plate	1
*	D-2550-232-TA0	Work clamp foot, right & left asm.	1
9	D-2550-232-T00	Work clamp foot, right	(1)
10	D-2551-232-T00	Work clamp foot, left	(1)
11	D-2516-232-T00	Feed scale	1
12	D-2526-322-V00	Feed across scale	1
13	B-2520-232-00B	Work clamp frame, for wide width	1
14	D-2545-232-N00	Slide plate, for feed plate carrier bar	1
15	D-2220-232-K00	Thread nipper tripping segment	1
16	D-2201-232-T00	Feed cam	1
30	D-2524-K0R-R00	Positioning pin, for work clamp foot bracket	2

○ All parts not mentioned above are same as those of model LK-232.

17) LK-232-19 GIRDLE SEWING MACHINE

Ref. No.	Part No.	Description	Amt. Req.
17	B-LKSUB00019	Subclass No. plate 19	1
18	D-2426-232-E00	Needle plate needle hole guide	1
19	D-2530-232-B00	Feed across stop roller	1
20	SS-7151330-SP	. . . Screw	1
21	D-2516-232-U00	Feed scale	1
22	D-2517-232-U00	Feed plate	1
*	D-2550-232-UA0	Work clamp foot, right & left asm.	1
23	D-2550-232-U00	Work clamp foot, right	(1)
24	D-2551-232-U00	Work clamp foot, left	(1)
25	D-2524-232-U00	Feed across scale	1
26	B-2520-232-00B	Work clamp frame, for wide width	1
27	D-2545-232-N00	Slide plate, for feed plate carrier bar	1
28	D-2220-232-K00	Thread nipper tripping segment	1
29	D-2209-232-U00	Feed cam	1

○ All parts not mentioned above are same as those of model LK-232.

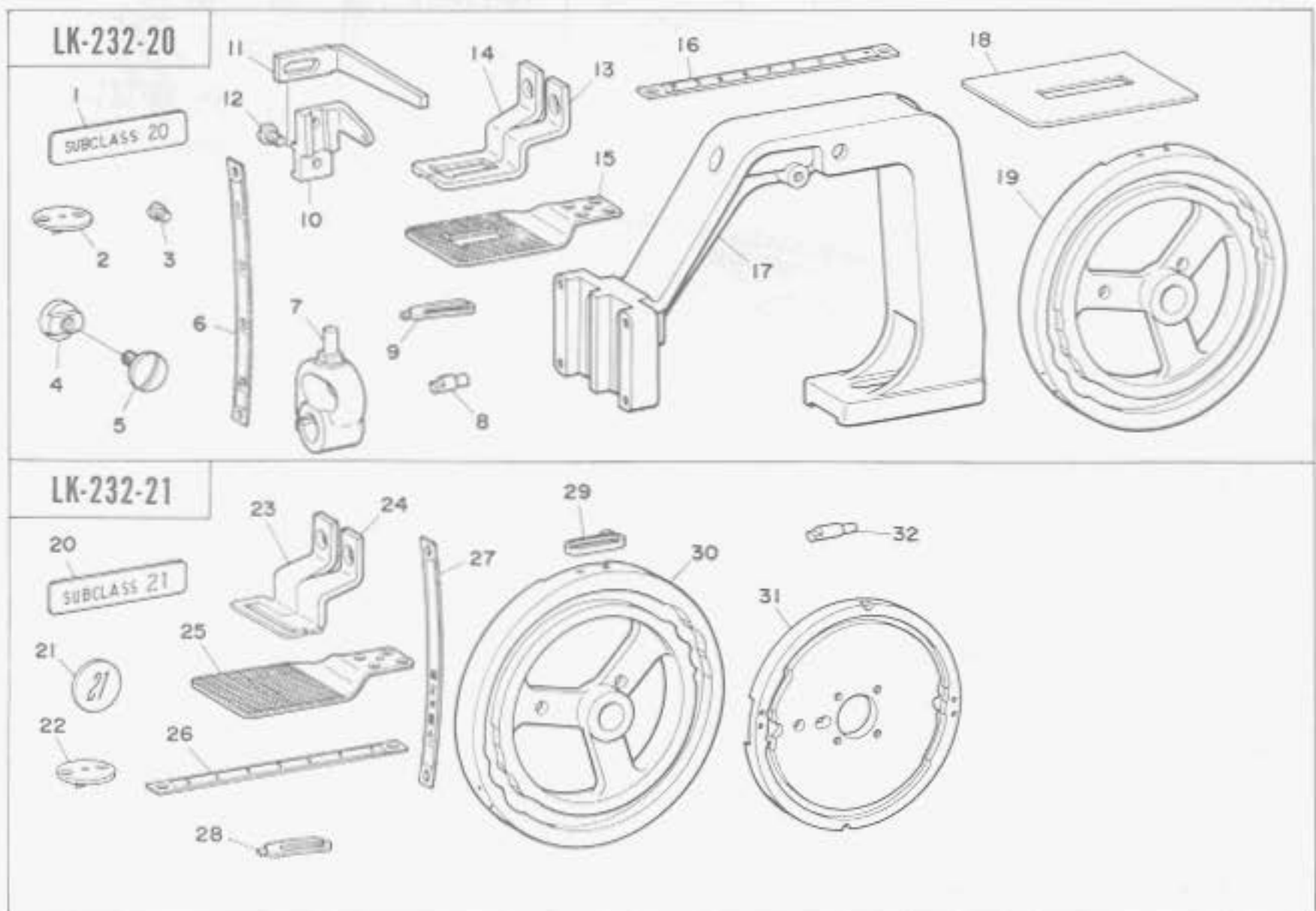

18) LK-232-20 RECTANGLE SHAPED TACKING MACHINE

Ref. No.	Part No.	Description	Amt. Req.
1	B-LKSUB00020	Subclass No. plate 20	1
2	D-2426-232-E00	Needle plate needle hole guide	1
3	SS-6090440-SP	Feed regulator stop screw	1
4	D-2530-232-B00	Feed across stop roller	1
5	SS-7151330-SP	... Screw	1
6	D-2516-232-U00	Feed scale	1
7	D-2541-232-GA0	Feed across shaft crank, front B asm.	1
8	D-2524-K0R-R00	Positioning pin, for work clamp foot bracket	2
9	D-2220-232-K00	Thread nipper tripping segment	1
10	B-1503-232-00B	Clamp foot lifting base	1
11	B-1501-232-00B	Clamp foot lifting lever	1
12	SS-7110820-SP	... Adjusting screw	1
*	D-2550-232-VA0	Work clamp foot, right & left asm.	1
13	D-2550-232-V00	Work clamp foot, right	(1)
14	D-2551-232-V00	Work clamp foot, left	(1)
15	D-2517-232-V00	Feed plate	1
16	D-2526-322-V00	Feed across scale	1
17	B-2520-232-00B	Work clamp frame, for wide width	1
18	D-2545-232-N00	Slide plate, for feed plate carrier bar	1
19	D-2209-232-V00	Feed cam	1
○	All parts not mentioned above are same as those of model LK-232.		

19) LK-232-21 SLEEVE PLACKET SEWING MACHINE

Ref. No.	Part No.	Description	Amt. Req.
20	B-LKSUB00021	Subclass No. plate 21	1
21	D-1116-232-B00	Stitch number plate, for 21 stitches	1
22	D-2426-232-E00	Needle plate needle hole guide	1
*	D-2550-232-HA0	Work clamp foot, right & left asm.	1
23	D-2551-232-H00	Work clamp foot, left	(1)
24	D-2550-232-H00	Work clamp foot, right	(1)
25	D-2517-232-H00	Feed plate	1
26	D-2526-322-D00	Feed across scale	1
27	D-2516-232-H00	Feed scale	1
28	D-2220-232-K00	Thread nipper tripping segment	2
29	D-2214-232-B00	Stop tripping segment B, for 21 stitches	2
30	D-2209-232-W00	Feed cam	1
31	D-2211-232-B00	Knife cam	1
32	D-2524-K7R-Y00	Positioning pin, for work clamp foot bracket	2
○	All parts not mentioned above are same as those of model LK-232.		

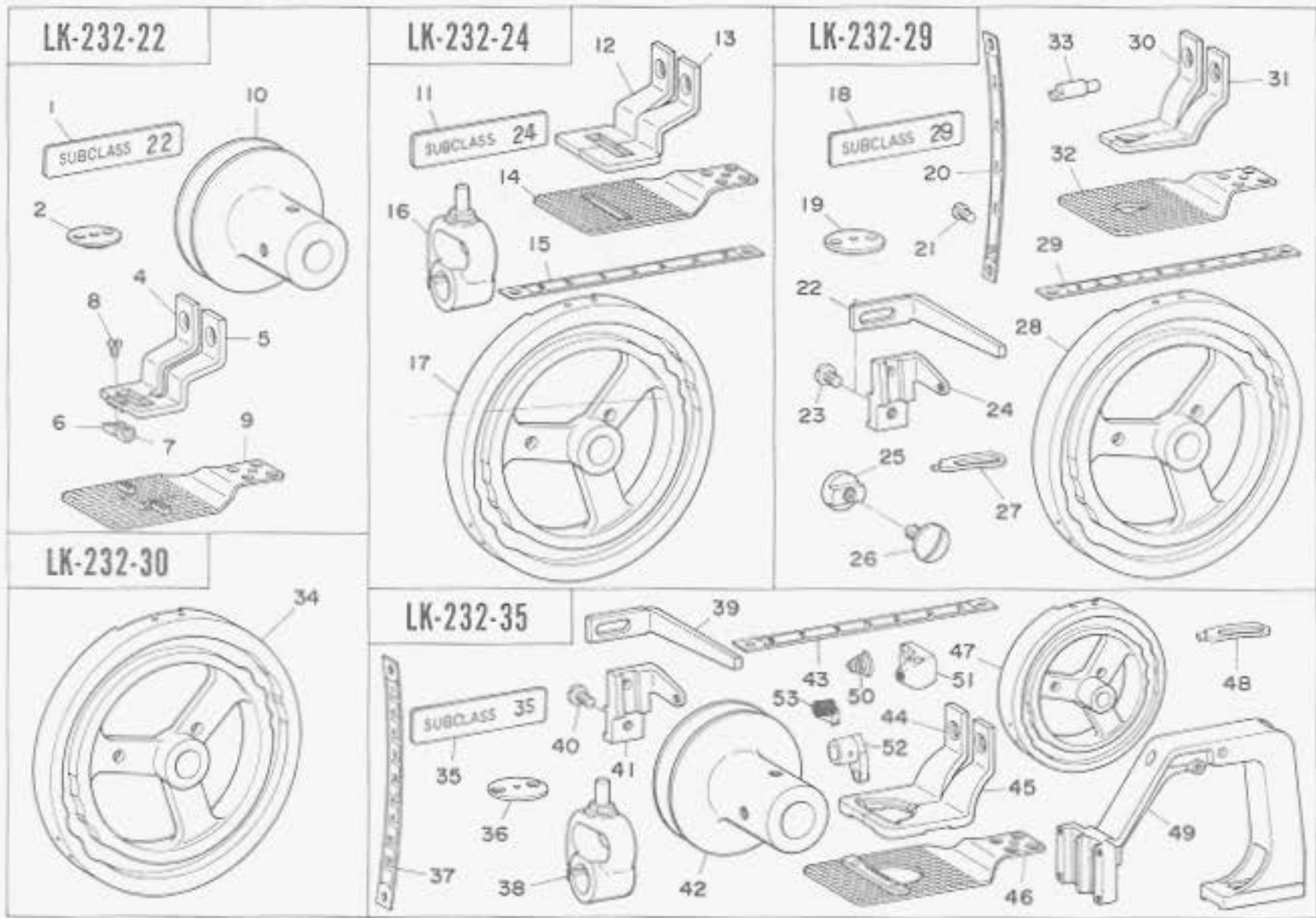

20) LK-232-22 LAVER NET BAR TACKING MACHINE

Ref. No.	Part No.	Description	Amt. Req.
1	B-LKSUB00022	Subclass No. plate 22	1
2	D-2426-232-X00	Needle plate needle hole guide	1
*	D-2550-232-XA0	Work clamp foot, right & left asm.	1
4	D-2551-232-X00	Work clamp foot, left	(1)
5	D-2550-232-X00	Work clamp foot, right	(1)
6	D-2557-232-X00	Rope holder, left	1
7	D-2556-232-X00	Rope holder, right	1
8	SS-6080410-SP	. . . Screw	2
9	D-2517-232-X00	Feed plate	1
	B-2429-232-000	. . . Pin	4
	D-2555-232-X00	Rope guide	2
10	D-7102-232-X00	Motor pulley (1300 s.p.m.), 60Hz	1
	D-7101-232-X00	Motor pulley (1300 s.p.m.), 50Hz	(1)
○	All parts not mentioned above are same as those of model LK-232.		

21) LK-232-24 LARGE BAR TACKING MACHINE

Ref. No.	Part No.	Description	Amt. Req.
11	B-LKSUB00024	Subclass No. plate 24	1
*	D-2550-232-ZA0	Work clamp foot, right & left asm.	1
12	D-2551-232-Z00	Work clamp foot, left	(1)
13	D-2550-232-Z00	Work clamp foot, right	(1)
14	D-2517-232-Z00	Feed plate	1
15	D-2526-322-V00	Feed across scale	1
16	D-2541-232-GA0	Feed across shaft crank, front B asm.	1
17	D-2209-232-Z00	Feed cam	1
○	All parts not mentioned above are same as those of model LK-232.		

22) LK-232-29 TRIANGLE SEWING MACHINE

Ref. No.	Part No.	Description	Amt. Req.
18	B-LKSUB00029	Subclass No. plate 29	1
19	D-2426-232-E00	Needle plate needle hole guide	1
20	D-2516-232-M00	Feed scale	1
21	SS-6090440-SP	Feed regulator stop screw	1
22	B-1501-232-008	Clamp foot lifting lever	1
23	SS-7110820-SP	Adjusting screw, for clamp foot lifting base	1
24	B-1503-232-008	Clamp foot lifting base	1
25	D-2530-232-B00	Feed across stop roller	1

Ref. No.	Part No.	Description	Amt. Req.
26	SS-7151330-SP	. . . Screw	1
27	D-2220-232-K00	Thread nipper tripping segment	1
28	D-2209-K0A-E00	Feed cam	1
29	D-2526-232-F00	Feed across scale	1
*	D-2550-K0A-EA0	Work clamp foot, right & left asm.	1
30	D-2551-K0A-E00	Work clamp foot, left	(1)
31	D-2550-K0A-E00	Work clamp foot, right	(1)
32	D-2517-K0A-E00	Feed plate	1
33	D-2524-232-M00	Positioning pin, for work clamp foot bracket	2
○	All parts not mentioned above are same as those of model LK-232.		

23) LK-232-30 NET SEWING MACHINE

Ref. No.	Part No.	Description	Amt. Req.
34	D-2209-K0A-F00	Feed cam	1
○	All parts not mentioned above are same as those of model LK-232.		

24) LK-232-35 SEMI-CIRCULAR SHAPING MACHINE

Ref. No.	Part No.	Description	Amt. Req.
35	B-LKSUB00035	Subclass No. plate 35	1
36	D-2426-K95-E00	Needle plate needle hole guide	1
37	D-2516-232-S00	Feed scale	1
38	D-2541-232-GA0	Feed across shaft crank, front B asm.	1
39	B-1501-232-008	Clamp foot lifting lever	1
40	SS-7110820-SP	Adjusting screw, for work clamp foot lifting base	1
41	B-1503-232-008	Clamp foot lifting base	1
42	D-7102-232-X00	Motor pulley (1300 s.p.m.), 60Hz	1
	D-7101-232-X00	Motor pulley (1300 s.p.m.), 50Hz	(1)
43	D-2526-232-V00	Feed across scale	1
*	D-2550-K0A-LA0	Work clamp foot, right & left asm.	1
44	D-2551-K0A-L00	Work clamp foot, left	(1)
45	D-2550-K0A-L00	Work clamp foot, right	(1)
46	D-2517-K0A-L00	Feed plate	1
47	D-2209-K0A-L00	Feed cam	1
48	D-2220-232-K00	Thread nipper tripping segment	1

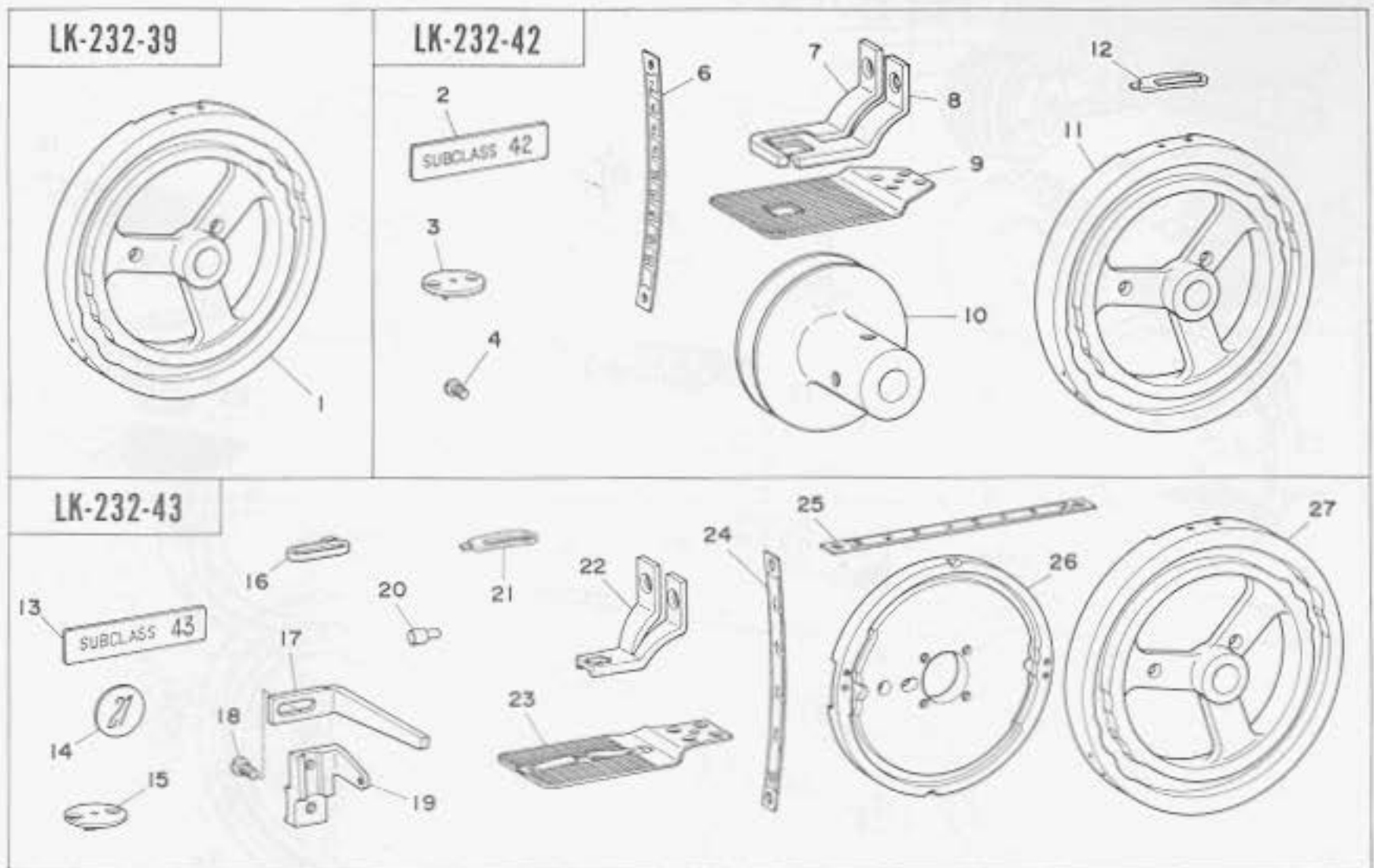

49	B-2520-232-008	Work clamp frame, for wide width	1
50	B-3129-053-000	Tension spring, No.2	1
51	D-1504-K9S-E00	Presser bar lifting bracket	1
52	D-1806-K9S-E00	Shuttle driver shaft crank	1
53	D-3128-K9S-E00	Take-up spring	1
○	All parts not mentioned above are same as those of model LK-232.		

25) LK-232-39 VERTICAL LONG SHAPE SEWING MACHINE

Ref. No.	Part No.	Description	Amt. Req.
1	D-2209-K0A-Q00	Feed cam	1
○	All parts not mentioned above are same as those of model LK-232.		

26) LK-232-42 DOUBLE SQUARE SHAPE SEWING MACHINE

2	B-LKSUB00042	Subclass No. plate 42	1
3	D-2426-232-E00	Needle plate needle hole guide	1
4	SS-6090440-SP	Feed regulator stop screw	1
6	D-2516-232-S00	Feed scale	1
*	D-2550-K0A-TA0	Work clamp foot, right & left asm.	1
7	D-2551-K0A-T00	Work clamp foot, left	(1)
8	D-2550-K0A-T00	Work clamp foot, right	(1)
9	D-2517-K0A-T00	Feed plate	1
10	D-7102-232-X00	Motor pulley (1300 s.p.m.), 60Hz	1
	D-7101-232-X00	Motor pulley (1300 s.p.m.), 50Hz	(1)
11	D-2209-K0A-T00	Feed cam	1
12	D-2220-232-K00	Thread nipper tripping segment	1

○ All parts not mentioned above are same as those of model LK-232.

27) LK-232-43 BAND LOOP ATTACHING SEWING MACHINE

Ref. No.	Part No.	Description	Amt. Req.
13	B-LKSUB00043	Subclass No. plate 43	1
14	D-1116-232-B00	Stitch number plate, for 21 stitches	1
15	D-2426-232-E00	Needle plate needle hole guide	1
16	D-2214-232-B00	Stop tripping segment B	2
17	B-1501-232-008	Clamp foot lifting lever	1
18	SS-7110820-SP	Adjusting screw, for clamp foot lifting base	1
19	B-1503-232-008	Clamp foot lifting base	1
20	D-2524-K7R-U00	Positioning pin, for work clamp foot bracket	2
21	D-2220-232-K00	Thread nipper tripping segment	2
22	D-2551-K0A-U00	Work clamp foot	1
23	D-2517-K0A-U00	Feed plate	1
24	D-2516-232-M00	Feed scale	1
25	D-2526-232-E00	Feed across scale	1
26	D-2211-232-B00	Knife cam	1
27	D-2209-K0A-U00	Feed cam	1

○ All parts not mentioned above are same as those of model LK-232.

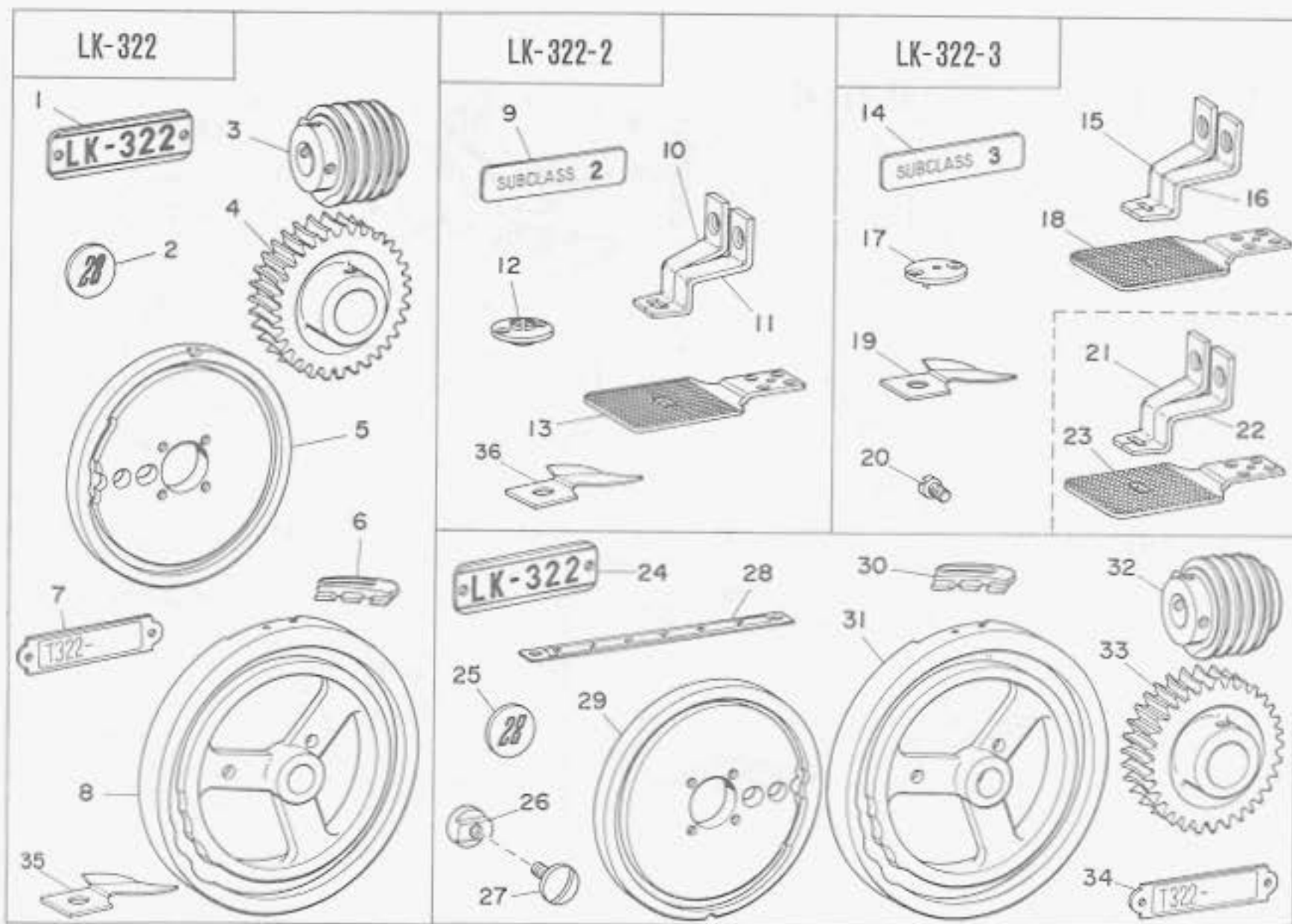

28) LK-322 Tail of eyelet buttonhole bar tacking

Ref. No.	Part No.	Description	Amt. Req.
1	B-1112-322-000	Model plate	1
2	B-1116-322-000	Stitch number plate, for 28 stitches	1
3	B-2207-322-000	Feed cam driving worm, for 28 stitches	1
4	B-2206-322-000	Feed cam driving worm wheel, for 28 stitches	1
5	B-2211-322-000	Knife cam, for 28 stitches	1
6	B-2220-322-000	Thread nipper tripping segment, for 28 stitches	1
7	B-1199-322-000	Number plate	1
8	B-2209-322-000	Feed cam, for 28 stitches	1
35	D-2423-232-C00	Needle thread knife	1
○	All parts not mentioned above are same as those of model LK-232-4.		

29) LK-322-2 Smaller bar tacking

9	B-LKSUB00002	Subclass No. plate 2	1
*	D-2550-232-BA0	Work clamp foot complete	1
10	D-2551-232-B00	Work clamp foot, left	(1)
11	D-2550-232-B00	Work clamp foot, right	(1)
12	D-2426-232-B00	Needle plate needle hole guide	1
13	D-2517-232-B00	Feed plate	1
*24	B-1112-322-000	Model plate	1
*25	B-1116-322-000	Stitch number plate, for 28 stitches	1
*26	D-2530-232-B00	Feed across stop roller	1
*27	SS-7151330-SP	. . . Screw	1
*28	D-2526-232-B00	Feed scale	1

Ref. No.	Part No.	Description	Amt. Req.
*29	B-2211-322-000	Knife cam, for 28 stitches	1
*30	B-2220-322-000	Thread nipper tripping segment, for 28 stitches	1
*31	B-2209-322-000	Feed cam, for 28 stitches	1
*32	B-2207-322-000	Feed cam driving worm, for 28 stitches	1
*33	B-2206-322-000	Feed cam driving worm wheel, for 28 stitches	1
*34	B-1199-322-000	Number plate	1
36	D-2423-232-C00	Needle thread knife	1
○	All parts not mentioned above are same as those of model LK-232.		

30) LK-322-3 Knit goods bar tacking

14	B-LKSUB00003	Subclass No. plate 3	1
*	D-2550-232-CA0	Work clamp foot complete	1
15	D-2551-232-C00	Work clamp foot, left	(1)
16	D-2550-232-C00	Work clamp foot, right	(1)
17	D-2426-232-E00	Needle plate needle hole guide	1
18	D-2517-232-C00	Feed plate	1
19	D-2423-232-C00	Needle thread knife	1
20	SS-6090440-SP	Feed regulator stop screw	1
(21)	D-2551-232-C0A	Work clamp foot, left, large	(1)
(22)	D-2550-232-C0A	Work clamp foot, right, large	(1)
(23)	D-2517-232-C0A	Feed plate, large	(1)
○	All parts not mentioned above are same as those of model LK-232, but (*) marks of model LK-322-2 are also same as this model.		

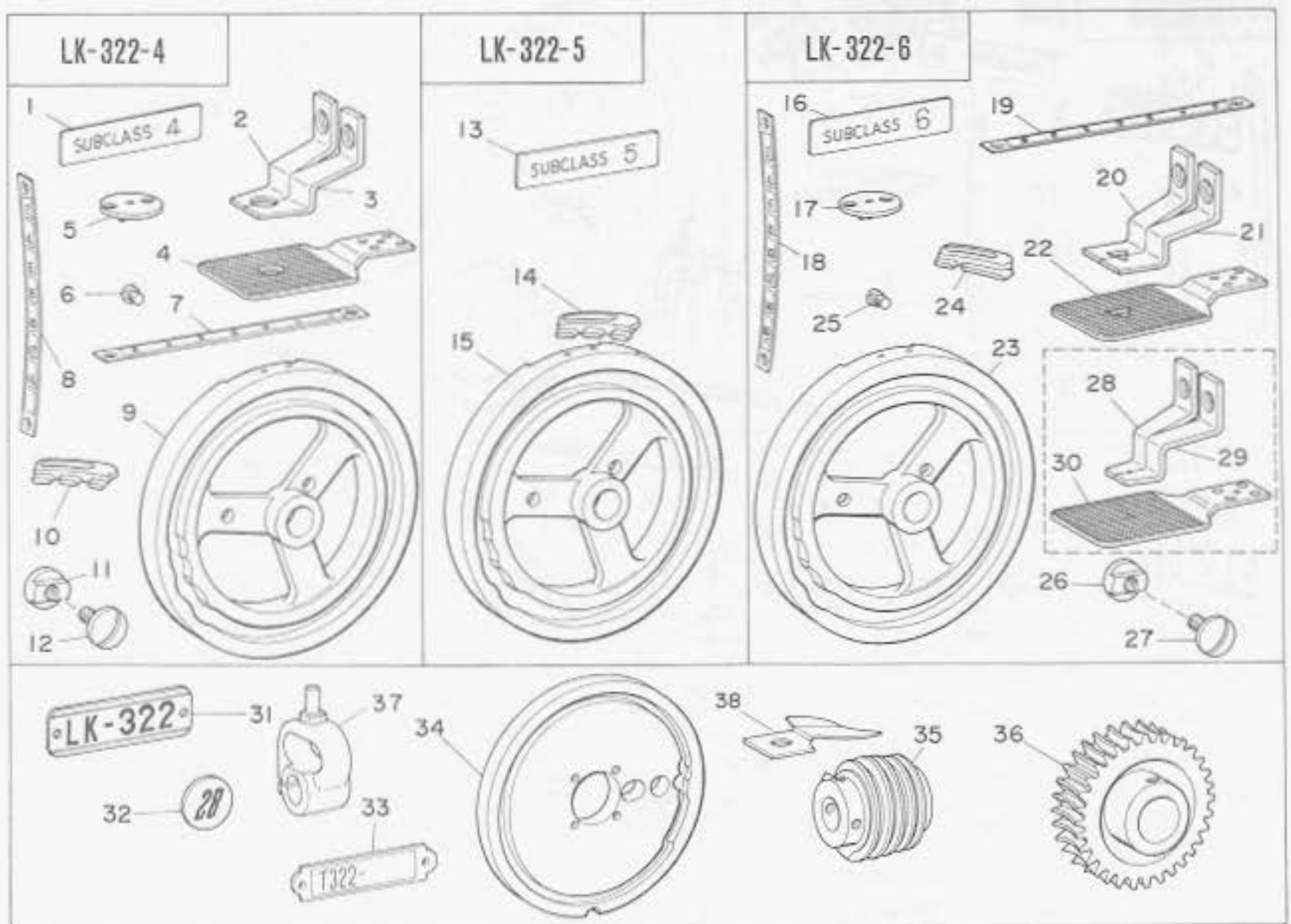

31) LK-322-4 Round shaped bar tacking

Ref. No.	Part No.	Description	Amt. Req.
1	B-LKSUB00004	Subclass No. plate	1
*	D-2550-232-DA0	Work clamp foot complete	1
2	D-2551-322-D00	Work clamp foot, left	(1)
3	D-2550-322-D00	Work clamp foot, right	(1)
4	D-2517-322-D00	Feed plate	1
5	D-2426-232-E00	Needle plate needle hole guide, for special tacks	1
6	SS-6090440-SP	Feed regulator stop screw	1
7	D-2526-322-D00	Feed across scale	1
8	D-2516-322-D00	Feed scale	1
9	D-2209-322-D00	Feed cam, for 28 stitches	1
10	D-2220-KIA-A00	Thread nipper tripping segment	1
11	D-2530-232-B00	Feed across stop roller	1
12	SS-7151330-SP	. . . Screw	1
*31	B-1112-322-000	Model plate	1
*32	B-1116-322-000	Stitch No. plate, for 28 stitches	1
*33	B-1199-322-000	Number plate	1
*34	B-2211-322-000	Knife cam, for 28 stitches	1
*35	B-2207-322-000	Feed cam driving worm, for 28 stitches	1
*36	B-2206-322-000	Feed cam driving worm wheel, for 28 stitches	1
*38	D-2423-232-C00	Needle thread knife	1
○	All parts not mentioned above are same as those of model LK-232.		

32) LK-322-5 Bar tacking (28 stitches)

13	B-LKSUB00005	Subclass No. plate 5	1
14	B-2220-322-000	Thread nipper tripping segment	1

Ref. No.	Part No.	Description	Amt. Req.
15	D-2209-322-E00	Feed cam	1
*38	D-2423-232-C00	Needle thread knife	1
○	All parts not mentioned above are same as those of model LK-232, but (+) marks of model LK-322-4 are also same as this model.		

33) LK-322-6 Right sided triangle shaping

16	B-LKSUB00006	Subclass No. plate 6	1
17	D-2426-232-E00	Needle plate needle hole guide, for special tacks	1
18	D-2516-322-F00	Feed scale	1
19	D-2526-322-D00	Feed across scale	1
*	D-2550-232-FA0	Work clamp foot complete	1
20	D-2551-322-F00	Work clamp foot, left	(1)
21	D-2550-322-F00	Work clamp foot, right	(1)
22	D-2517-322-F00	Feed plate	1
23	D-2209-322-F00	Feed cam	1
24	D-2220-KIA-A00	Thread nipper tripping segment	1
25	SS-6090440-SP	Feed regulator stop screw	1
26	D-2530-232-B00	Feed across stop roller	1
27	SS-7151330-SP	. . . Screw	1
(28)	D-2551-322-FOB	Work clamp foot blank, left	(1)
(29)	D-2550-322-FOB	Work clamp foot blank, right	(1)
(30)	D-2517-322-FOB	Feed plate blank	(1)
37	D-2541-232-GA0	Feed across shaft crank, front, asm.	1
38	D-2423-232-C00	Needle thread knife	1
○	All parts not mentioned above are same as those of model LK-232, but (+) marks of model LK-322-4 are also same as this model.		

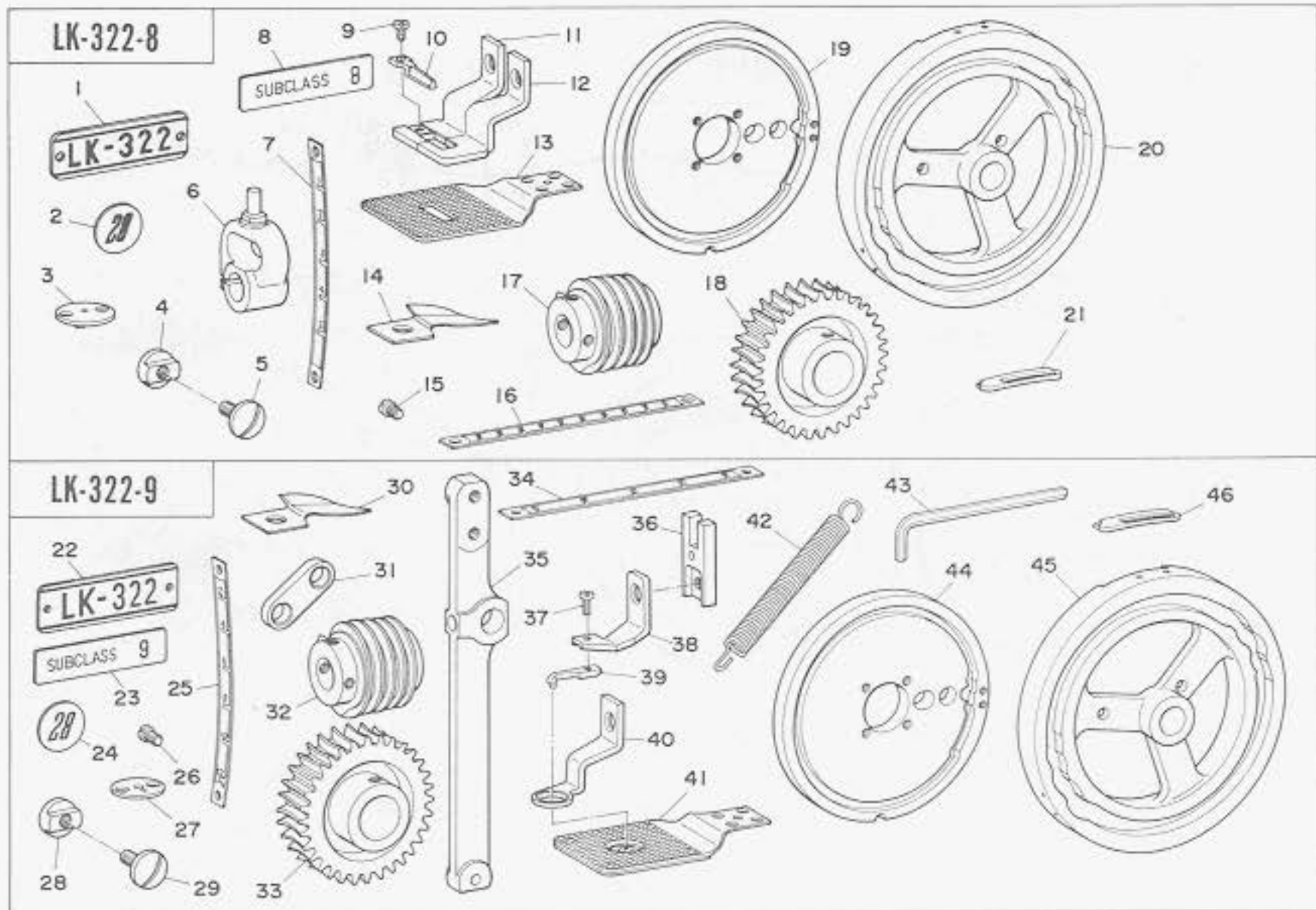

34) LK-322-8 TOPSTITCH SEWING MACHINE FOR BREAST POCKET FACING

Ref. No.	Part No.	Description	Amt. Req.
1	B-1112-322-000	Model plate	1
2	B-1116-322-000	Stitch number plate, for 28 stitches	1
3	D-2426-232-E00	Thread nipper tripping segment	1
4	D-2530-232-B00	Feed across stop roller	1
5	SS-7151330-SP	... Screw	1
6	D-2541-232-GA0	Feed across shaft crank, front B asm.	1
7	D-2516-322-H00	Feed scale	1
8	B-LKSUB00008	Subclass No. plate 8	1
9	SS-7090510-SP	Intermediate clamp foot set screw	1
10	D-2552-322-H00	Intermediate clamp foot	1
11	D-2550-322-HA0	Work clamp foot, right & left asm.	1
12	D-2551-322-H00	Work clamp foot, left	(1)
13	D-2550-322-H00	Work clamp foot, right	(1)
14	D-2517-322-H00	Feed plate	1
15	D-2423-232-C00	Needle thread knife	1
16	SS-6090440-SP	Feed regulator stop screw	1
17	D-2526-232-G00	Feed scale	1
18	B-2207-322-000	Feed cam driving worm	1
19	B-2206-322-000	Feed cam driving worm wheel	1
20	B-2211-322-000	Knife cam	1
21	D-2209-322-H00	Feed cam	1
22	D-2220-K1A-A00	Thread nipper tripping segment	1
○	All parts not mentioned above are same as those of model LK-232.		

35) LK-322-9 SNAP FASTENER ATTACHING MACHINE

22	B-1112-322-000	Model plate	1
23	B-LKSUB00009	Subclass No. plate 9	1
24	B-1116-322-000	Stitch number plate, for 28 stitches	1
25	D-2516-322-J00	Feed scale	1
26	SS-6090440-SP	Feed regulator stop screw	1
27	D-2426-322-J00	Needle plate needle hole guide	1
28	D-2530-232-B00	Feed across stop roller	1

29	SS-7151330-SP	... Screw	1
30	D-2423-232-C00	Needle thread knife	1
31	D-1510-322-J00	... Driving link	1
32	B-2207-322-000	Feed cam driving worm	1
33	B-2206-322-000	Feed cam driving worm gear	1
34	D-2526-322-J00	Feed across scale	1
35	D-2401-322-J00	Knife bar tripping lever	1
36	D-2553-232-K00	Work clamp foot bracket	1
37	SS-6080652-TP	Snap fastner clamp foot set screw	1
38	D-2561-322-J00	Snap fastner clamp foot installing plate	1
39	D-2550-322-J00	Snap fastner clamp foot, 8 mm	1
	D-2550-322-J0B	Snap fastner clamp foot, 7 mm	(1)
	D-2550-322-J0C	Snap fastner clamp foot, 5 mm	(1)
	D-2550-322-J0D	Snap fastner clamp foot, 10 mm	(1)
	D-2550-322-J0E	Snap fastner clamp foot, 12 mm	(1)
40	D-2551-322-J00	Work clamp foot, left	1
41	D-2517-322-J00	Feed plate	1
	D-2560-322-J00	Snap fastner receiver	1
	D-2556-322-J00	... Pin	4
	D-2517-322-J0B	Feed plate, for 5 mm snap fastner	(1)
	D-2560-322-J0B	Snap fastner receiver, 5 mm snap	(1)
	D-2517-322-J0C	Feed plate, for 12 mm snap fastner	(1)
	D-2560-322-J0C	Snap fastner receiver, 12 mm snap	(1)
42	D-2546-232-K00	Pressure spring	1
43	D-9140-322-J00	Box spanner	1
44	B-2211-322-000	Knife cam	1
45	D-2209-322-J00	Feed cam	1
46	D-2220-K1A-A00	Thread nipper tripping segment	1
○	All parts not mentioned above are same as those of model LK-232.		

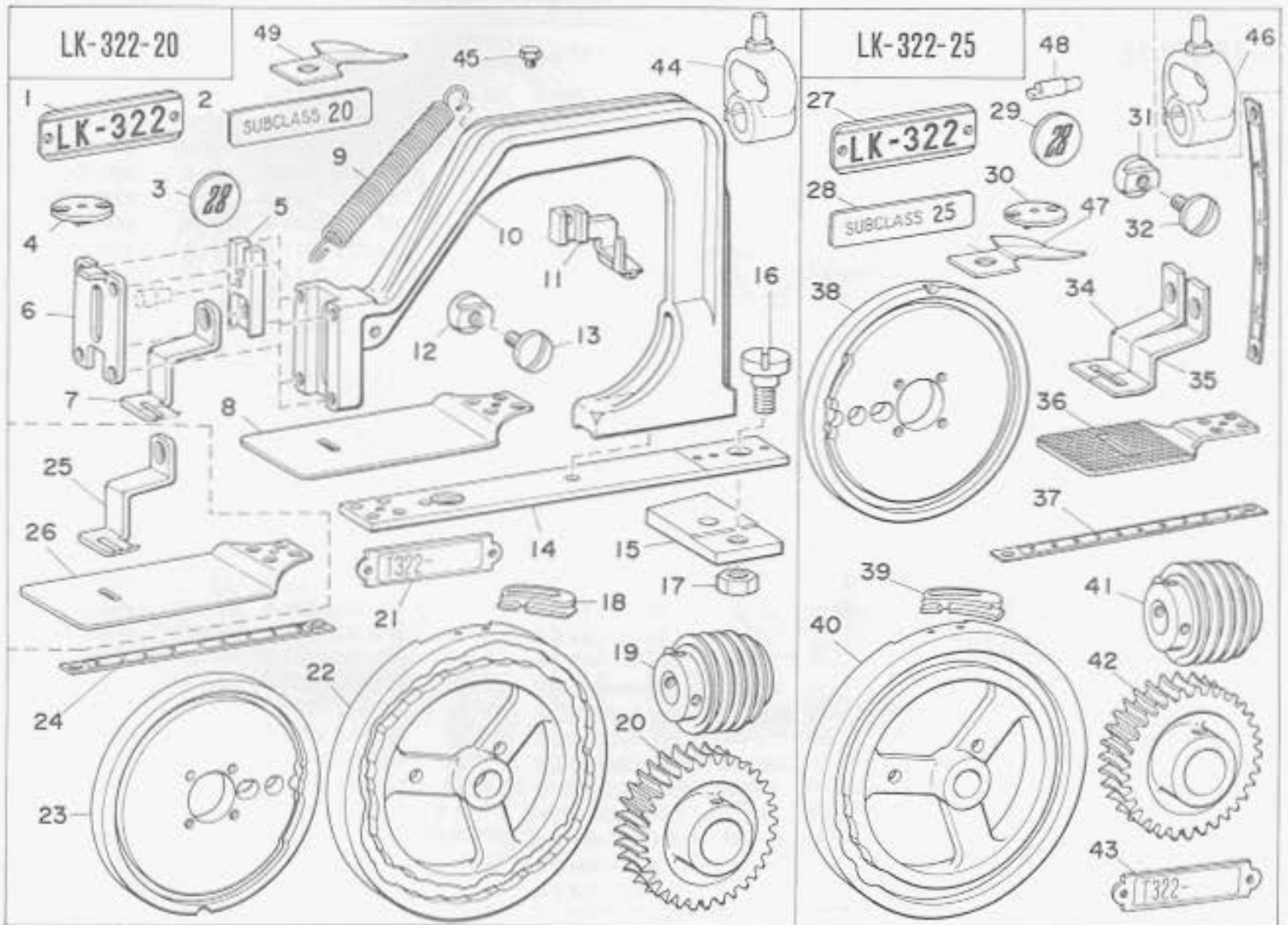

36) LK-322-20 Band loop attaching

Ref. No.	Part No.	Description	Amt. Req.
1	B-1112-322-000	Model plate	1
2	B-LKSUB00020	Subclass No. plate 20	1
3	B-1116-322-000	Stitch number plate, for 28 stitches	1
4	D-2426-232-E00	Needle plate needle hole, guide, special tacks	1
5	D-2523-232-K00	Work clamp foot bracket	1
6	D-2525-232-K00	Work clamp face plate	1
7	D-2550-232-K00	Work clamp foot	1
8	D-2517-232-K00	Feed plate	1
9	D-2546-232-K00	Pressure spring	1
10	D-2520-232-K00	Work clamp frame	1
11	D-1501-232-K00	Clamp foot lifting lever	1
12	D-2530-232-B00	Feed across stop roller	1
13	SS-7151330-SP	. . . Screw	1
14	D-2512-232-K00	Feed plate carrier	1
15	D-2519-232-K00	. . . Guide plate	1
16	SD-0950491-SP	. . . Hinge screw	1
17	NS-6660430-SP	. . . Nut	1
18	B-2220-322-000	Thread nipper tripping segment, for 28 stitches	1
19	B-2207-322-000	Feed cam driving worm, for 28 stitches	1
20	B-2206-322-000	Feed cam driving worm wheel, for 28 stitches	1
21	B-1199-322-000	Number plate	1
22	D-2209-322-V00	Feed cam, for 28 stitches	1
23	B-2211-322-000	Knife cam, for 28 stitches	1
24	D-2526-322-V00	Feed across scale, 28 stitches	1
44	D-2541-232-GA0	Feed across shaft crank, front, asm.	1
45	SS-9110543-CP	Bolt, for feed plate	1
49	D-2423-232-C00	Needle thread knife	1

Ref. No.	Part No.	Description	Amt. Req.
(25)	D-2550-322-V00	Work clamp foot, large	(1)
(26)	D-2517-322-V00	Feed plate, large	(1)
○	All parts not mentioned above are same as those of model LK-232.		
37) LK-322-25 Straight lined shaping			
27	B-1112-322-000	Model plate	1
28	B-LKSUB00025	Subclass No. plate 25	1
29	B-1116-322-000	Stitch number plate, for 28 stitches	1
30	D-2426-232-E00	Needle plate needle hole guide, for special tacking	1
31	D-2530-232-B00	Feed across stop roller	1
32	SS-7151330-SP	. . . Screw	1
33	D-2516-KIA-A00	Feed scale, for 28 stitches	1
*	D-2550-232-HA0	Work clamp foot complete	1
34	D-2551-232-H00	Work clamp foot, left	(1)
35	D-2550-232-H00	Work clamp foot, right	(1)
36	D-2517-KIA-A00	Feed plate	1
37	D-2526-232-G00	Feed scale	1
38	B-2211-322-000	Knife cam, for 28 stitches	1
39	D-2220-KIA-A00	Thread nipper tripping segment, for 28 stitches	1
40	D-2209-KIA-A00	Feed cam	1
41	B-2207-322-000	Feed cam driving worm, for 28 stitches	1
42	B-2206-322-000	Feed cam driving worm wheel, for 28 stitches	1
43	B-1199-322-000	Number plate	1
46	D-2541-232-GA0	Feed across shaft crank, front, asm.	(1)
47	D-2423-232-C00	Needle thread knife	1
48	D-2524-232-M00	. . . Pin	2
○	All parts not mentioned above are same as those of model LK-232.		

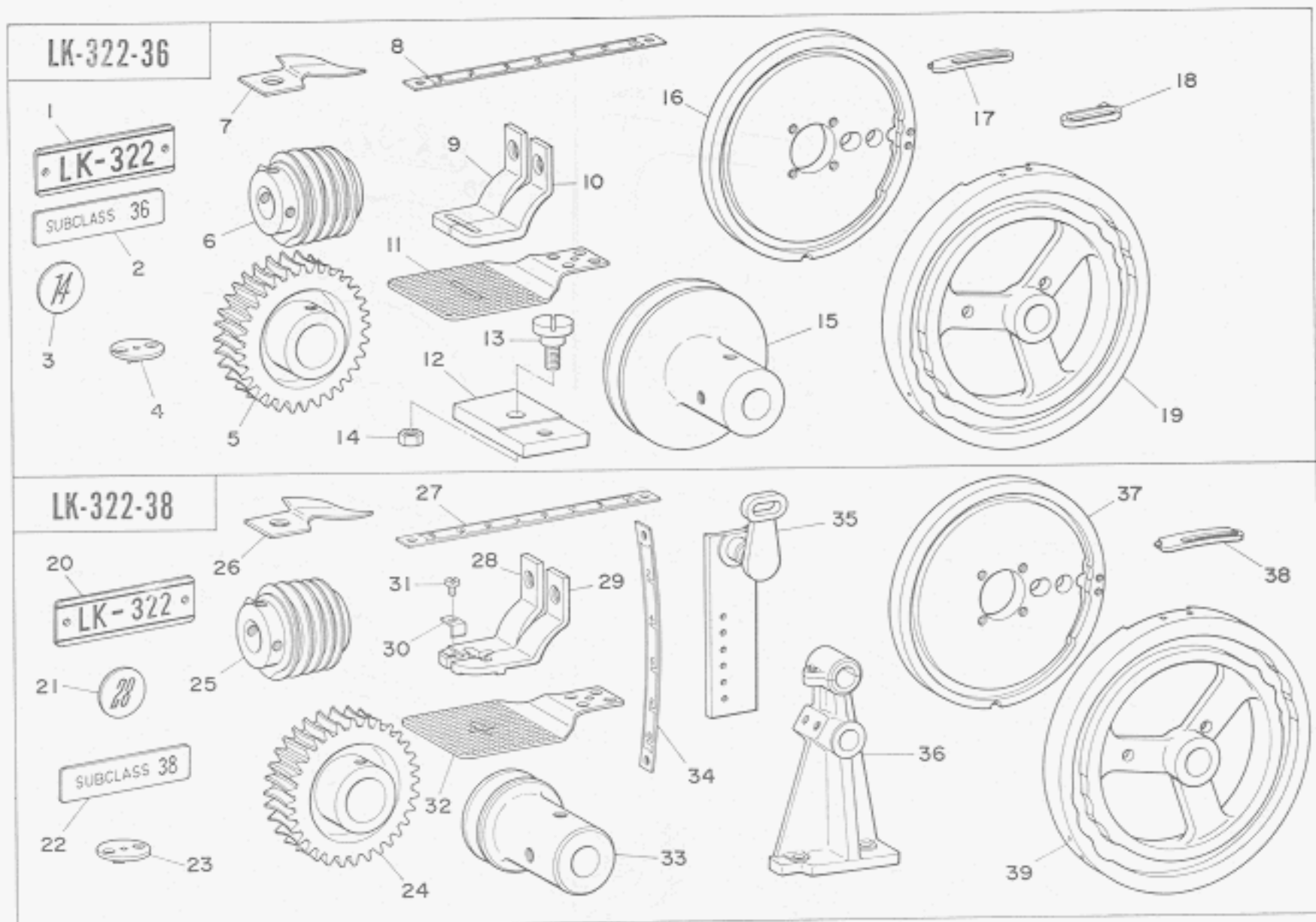

38) LK-322-36 STRAIGHT LINE SEWING MACHINE

Ref. No.	Part No.	Description	Amt. Req.
1	B-1112-322-000	Model plate	1
2	B-LKSUB00036	Subclass No. plate 36	1
3	D-1116-K1A-M00	Stitch number plate, for 14 stitches	1
4	D-2426-232-E00	Needle plate needle hole guide	1
5	B-2206-322-000	Feed cam driving worm gear	1
6	B-2207-322-000	Feed cam driving worm	1
7	D-2423-232-C00	Needle thread knife	1
8	D-2526-322-D00	Feed across scale	1
*	D-2550-K1A-MA0	Work clamp foot, right & left asm.	1
9	D-2551-K1A-M00	Work clamp foot, left	(1)
10	D-2550-K1A-M00	Work clamp foot, right	(1)
11	D-2517-K1A-M00	Feed plate	1
12	D-2519-232-K00	Guide plate, for feed plate carrier bar	1
13	SD-0950491-SP	. . . Hinge screw	1
14	NS-6660430-SP	. . . Nut	1
15	D-7101-232-X00	Motor pulley (1300 s.p.m.), 50 Hz	1
	D-7102-232-X00	Motor pulley (1300 s.p.m.), 60 Hz	(1)
16	D-2211-K1A-M00	Knife cam	1
17	D-2220-K1A-A00	Thread nipper tripping segment	2
18	D-2214-232-B00	Stop tripping segment B, for 21 stitches	2
19	D-2209-K1A-M00	Feed cam	1
○	All parts not mentioned above are same as those of model LK-232.		

39) LK-322-38 X-SHAPED TACKING MACHINE

Ref. No.	Part No.	Description	Amt. Req.
20	B-1112-322-000	Model plate	1
21	B-1116-322-000	Stitch number plate, for 28 stitches	1
22	B-LKSUB00038	Subclass No. plate 38	1
23	D-2426-232-E00	Needle plate needle hole guide	1
24	B-2206-322-000	Feed cam driving worm gear	1
25	B-2207-322-000	Feed cam driving worm	1
26	D-2423-232-C00	Needle thread knife	1
27	D-2526-232-E00	Feed across scale	1
*	D-2550-K1A-PA0	Work clamp foot, right & left asm.	1
28	D-2551-K1A-P00	Work clamp foot, left	(1)
29	D-2550-K1A-P00	Work clamp foot, right	(1)
30	D-2580-K1A-P00	Work clamp guide	1
31	SS-4080310-SP	. . . Screw	1
32	D-2517-K1A-P00	Feed plate	1
33	D-7101-K1A-P00	Motor pulley (800 s.p.m.), 50Hz	(1)
	D-7102-K1A-P00	Motor pulley (800 s.p.m.), 60Hz	1
34	D-2516-K7A-C00	Feed scale	1
35	B-2501-232-00B	Feed regulator	1
36	B-2527-232-00B	Bearing bracket	1
37	B-2211-322-000	Knife cam	1
38	B-2220-322-000	Thread nipper tripping segment	1
39	D-2209-K1A-P00	Feed cam	1
○	All parts not mentioned above are same as those of model LK-232.		

13. NUMERICAL INDEX OF PARTS

Part No.	Page	Ref. No.	Part No.	Page	Ref. No.	Part No.	Page	Ref. No.	Part No.	Page	Ref. No.	Part No.	Page	Ref. No.
EXCLUSIVE PARTS														
A-1161-001-00B	1-25		B-1223-232-000	1-20		B-2007-232-000	5-15		B-2411-232-000	7-21		B-2618-232-000	10-41	
A-3222-958-000	2-31e		B-1227-232-000	1-38		B-2009-232-000	5-14		B-2413-232-000	7-18		B-2619-232-000	10-42	
A-9117-001-000	5-30		B-1228-232-000	1-37		B-2010-232-0A0	5-*12		B-2414-232-000	7-7		B-2621-232-000	10-43	
B-1101-232-0A0	1-11		B-1230-232-000	1-34		B-2011-232-000	5-13		B-2416-232-000	7-22		B-2623-232-000	10-33	
B-1103-232-000	1-28		B-1401-232-000	3-45		B-2013-232-000	5-7		B-2423-232-000	7-12		B-2632-232-000	10-3	
B-1104-232-000	1-29		B-1403-232-000	3-47		B-2014-232-000	5-9		B-2424-232-000	7-11		B-2633-232-000	10-4	
B-1105-232-0A0	1-27		B-1404-232-000	3-55		B-2015-232-0A0	5-4		B-2425-232-000	7-16		B-2636-232-000	11-12	
B-1107-232-000	1-15		B-1405-232-000	3-46		B-2018-232-000	3-51		B-2426-232-000	7-3		B-2639-232-0A0	11-8	
B-1109-232-000	1-21		B-1406-232-000	3-49		B-2020-232-000	5-5		B-2428-232-000	7-4		B-2640-232-000	11-1	
B-1110-232-000	1-30		B-1408-232-000	1-39		B-2021-232-000A	5-1		B-2429-232-000	7-5		B-2642-232-000	11-5	
B-1111-232-000	1-2		B-1414-232-000	3-53		B-2022-232-000A	5-2		B-2432-232-0A0	7-9		B-2643-232-000	11-13	
B-1112-232-000	1-24		B-1414-232-000	7-29		B-2101-232-000	4-41		B-2501-232-000	9-27		B-2645-232-000	11-7	
B-1112-322-000	24-1		B-1419-026-000	1-35		B-2102-232-000	4-39		B-2501-232-00B	28-35		B-2648-232-000	10-45	
B-1112-322-000	24-*24		B-1501-232-000	4-20		B-2104-232-000	4-38		B-2502-232-000	9-29		B-2650-232-000	11-22	
B-1112-322-000	25-*31		B-1501-232-00B	15-46		B-2105-232-000	4-21		B-2503-232-000	9-28		B-2651-232-000	10-15	
B-1112-322-000	27-1		B-1501-232-00B	18-22		B-2106-232-000	4-43		B-2505-232-000	8-24		B-2653-232-000	11-19	
B-1112-322-000	27-27		B-1501-232-00B	21-11		B-2107-232-000	4-44		B-2506-232-000	9-5		B-2654-232-000	11-20	
B-1112-322-000	26-1		B-1501-232-00B	22-22		B-2201-232-000	6-12		B-2507-232-000	9-6		B-2655-232-000	10-22	
B-1112-322-000	26-22		B-1501-232-00B	22-39		B-2202-232-000	6-24		B-2508-232-000	9-4		B-2656-232-000	10-14	
B-1112-322-000	28-1		B-1501-232-00B	23-17		B-2204-232-000	6-2		B-2510-232-000	9-1		B-2657-232-000	10-16	
B-1112-322-000	28-20		B-1502-232-000	4-18		B-2205-232-000	6-22		B-2511-232-000	9-2		B-2658-232-0A0	10-23	
B-1114-232-000	1-3		B-1503-232-00B	15-47		B-2206-232-000	6-17		B-2512-232-0A0	8-26		B-2659-232-000	11-21	
B-1115-232-000	2-24a		B-1503-232-00B	18-23		B-2206-322-000	24-4		B-2513-232-000	8-29		B-2661-232-000	10-13	
B-1115-232-0A0	2-*24		B-1503-232-00B	21-10		B-2206-322-000	24-*33		B-2515-232-000	8-27		B-2662-232-000	10-12	
B-1116-232-000	1-26		B-1503-232-00B	22-24		B-2206-322-000	25-*36		B-2516-232-000	9-20		B-3101-232-0B0	2-*22	
B-1116-322-000	24-2		B-1503-232-00B	22-41		B-2206-322-000	27-42		B-2517-232-000	8-17		B-3102-232-000	2-1	
B-1116-322-000	24-*25		B-1503-232-00B	23-19		B-2206-322-000	27-20		B-2518-232-000	9-3		B-3104-232-000	2-15	
B-1116-322-000	25-*32		B-1504-232-000	4-7		B-2206-322-000	26-18		B-2519-232-000	8-20		B-3105-232-000	2-23	
B-1116-322-000	27-3		B-1505-232-000	4-3		B-2206-322-000	26-33		B-2520-232-000	8-13		B-3106-232-000	2-18	
B-1116-322-000	27-29		B-1506-232-000	4-10		B-2206-322-000	28-5		B-2520-232-00B	20-13		B-3108-232-000	2-16	
B-1116-322-000	26-2		B-1507-232-000	4-24		B-2206-322-000	28-24		B-2520-232-00B	21-17		B-3109-232-000	2-5	
B-1116-322-000	26-24		B-1509-012-000	4-1		B-2207-232-000	3-26		B-2520-232-00B	20-26		B-3111-232-000	2-29	
B-1116-322-000	28-21		B-1510-232-000	4-12		B-2207-322-000	24-3		B-2520-232-00B	22-49		B-3112-232-000	2-27	
B-1118-232-000	1-8		B-1515-232-000	4-17		B-2207-322-000	24-*32		B-2521-232-000	8-14		B-3113-232-000	2-19	
B-1119-232-000	1-9		B-1516-232-000	4-9		B-2207-322-000	25-*35		B-2523-232-000	8-1		B-3113-232-0A0	2-*	
B-1120-232-000	1-16		B-1518-232-000	4-2		B-2207-322-000	27-19		B-2524-232-000	8-2		B-3114-232-000	2-7	
B-1121-232-000	1-18		B-1519-232-000	4-34		B-2207-322-000	27-41		B-2524-232-000	11-17		B-3116-125-000	2-9	
B-1122-232-000	1-14		B-1520-232-000	4-33		B-2207-322-000	26-17		B-2525-232-000	8-4		B-3117-352-000	14-31	
B-1125-232-000	1-12		B-1521-232-000	4-27		B-2207-322-000	26-32		B-2526-232-000	9-10		B-3120-125-000	2-8	
B-1159-041-000	1-23		B-1522-232-000	4-30		B-2207-322-000	28-6		B-2527-232-00B	28-36		B-3120-232-000	2-2	
B-1178-092-000	1-6		B-1523-232-000	4-5		B-2207-322-000	28-25		B-2527-232-000	9-*32		B-3121-232-000	2-3	
B-1199-232-000	1-33		B-1524-232-000	4-8		B-2209-232-000	6-15		B-2528-232-000	9-21		B-3122-232-000	2-17	
B-1199-322-000	24-7		B-1525-232-000	4-35		B-2209-322-000	24-8		B-2528-280-000	9-23		B-3123-352-000	2-24b	
B-1199-322-000	24-*34		B-1702-012-000	3-18		B-2209-322-000	24-*31		B-2529-232-000	9-30		B-3125-012-000	2-24c	
B-1199-322-000	25-*33		B-1801-232-0A0	5-39		B-2211-232-000	6-8		B-2531-232-000	9-22		B-3126-012-000	2-20	
B-1199-322-000	27-21		B-1804-232-000	5-34		B-2211-322-000	24-5		B-2532-232-000	1-31		B-3128-232-000	2-28	
B-1199-322-000	27-43		B-1805-232-000	5-50		B-2211-322-000	24-*29		B-2534-232-0A0	9-7		B-3129-053-000	22-50	
B-1201-232-000	3-22		B-1806-232-000	5-46		B-2211-322-000	25-*34		B-2536-232-000	9-8		B-3132-552-000	2-6	
B-1202-232-000	3-20		B-1807-232-000	5-52		B-2211-322-000	27-23		B-2537-232-0A0	9-*15		B-3201-232-000	2-31h	
B-1203-232-000	3-19		B-1809-232-000	5-33		B-2211-322-000	27-38		B-2539-232-000	9-25		B-3201-232-0A0	2-*31	
B-1204-232-000	3-32		B-1810-232-000	5-*28		B-2211-322-000	26-19		B-2541-232-000	9-*12		B-3202-232-000	2-31n	
B-1205-232-000	3-34		B-1812-232-000	5-25a		B-2211-322-000	26-44		B-2542-232-000	9-11		B-3203-232-000	2-31i	
B-1206-232-000	3-33		B-1812-232-0B0	5-*25		B-2211-322-000	28-37		B-2543-232-000	8-15		B-3204-232-000	2-31b	
B-1207-232-0A0A	3-31		B-1813-232-000	5-25b		B-2212-232-000	6-4		B-2544-232-000	8-16		B-3205-232-000	2-31e	
B-1208-232-000	3-38		B-1814-232-000	5-25c		B-2213-232-000	6-25		B-2545-232-000	8-31		B-3206-232-000	2-31c	
B-1209-232-000	3-40		B-1815-232-000	5-25d		B-2214-232-000	6-26		B-2546-232-000	8-9		B-3208-232-000	2-31d	
B-1210-232-000	3-39		B-1816-232-000	5-25g		B-2218-232-000	6-10		B-2550-232-000	8-7		B-3210-232-000	2-31k	
B-1211-232-000	3-35		B-1821-232-000	5-35		B-2220-232-000	6-14		B-2550-232-0A0	8-*		B-3211-232-000	2-32	
B-1212-232-000	3-41		B-1823-232-000	5-25f		B-2220-322-000	24-6		B-2551-232-000	8-6		B-3212-232-000	2-33	
B-1213-232-000	3-37		B-1824-232-0A0	5-32		B-2220-322-000	24-*30		B-2601-232-000	10-8		B-3213-232-000	2-34	
B-1214-232-000	3-24		B-1826-232-000	7-8		B-2220-322-000	25-14		B-2602-232-000	10-7		B-3214-047-000	2-35c	
B-1215-232-000	3-11		B-1827-232-000	5-43		B-2220-322-000	20-18		B-2604-232-000	10-6		B-3215-232-000	3-17	
B-1216-232-000A	3-16		B-1827-232-000	7-28		B-2220-322-000	28-38		B-2605-232-000	10-1		B-3216-047-000	2-35a	
B-1217-232-000	3-2		B-1828-232-000	5-42		B-2401-232-000	7-37		B-2606-232-000	10-17		B-3217-232-000	2-35e	
B-1217-232-0A0	3-*		B-1829-232-000	5-41		B-2402-232-000	7-34		B-2607-232-000	10-25		B-3217-232-0A0	2-*35	
B-1218-232-000A	3-6		B-1829-232-000	7-30		B-2403-232-000	7-35		B-2608-232-000	10-36		B-3218-232-000	2-35b	
B-1219-232-E00	3-5		B-1836-232-0A0	5-29		B-2407-232-000	7-23		B-2611-232-000	10-35		B-3219-232-000	2-35d	
B-1220-232-000	3-4		B-1901-232-0A0	2-12		B-2408-232-000	7-38		B-2612-232-000	10-38		B-3506-761-000	1-41	
B-1221-232-000	3-14		B-2001-232-000											

Part No.	Page	Ref. No.	Part No.	Page	Ref. No.	Part No.	Page	Ref. No.	Part No.	Page	Ref. No.	Part No.	Page	Ref. No.
B-3541-012-000		1-40	D-2209-232-B00		13-16	D-2220-232-K00		21-9	D-2516-232-E00		17-7	D-2520-232-K00		17-22
B-9101-232-000		5-31	D-2209-232-E00		15-12	D-2220-232-K00		22-27	D-2516-232-L00		15-36	D-2520-232-K00		27-10
B-LKSUB00002		12-1	D-2209-232-F00		15-26	D-2220-232-K00		22-48	D-2516-232-L00		18-6	D-2521-232-DA0		14-26
B-LKSUB00002		24-9	D-2209-232-G00		15-41	D-2220-232-K00		23-21	D-2516-232-M00		18-17	D-2522-232-D00		14-24
B-LKSUB00003		12-13	D-2209-232-J00		17-11	D-2220-232-K00		21-28	D-2516-322-F00		25-18	D-2523-232-K00		17-17
B-LKSUB00003		24-14	D-2209-232-K00		17-29	D-2220-232-K00		23-12	D-2516-K1A-A00		27-33	D-2523-232-K00		27-5
B-LKSUB00004		13-1	D-2209-232-L00		18-8	D-2220-K1A-A00		25-10	D-2516-232-H00		16-14	D-2523-232-K00		20-7
B-LKSUB00004		25-1	D-2209-232-M00		18-18	D-2220-K1A-A00		25-24	D-2516-232-H00		21-27	D-2523-232-K00		27-47
B-LKSUB00005		15-1	D-2209-232-H00		16-12	D-2220-K1A-A00		27-39	D-2516-322-H00		26-7	D-2524-232-M00		15-29
B-LKSUB00005		25-13	D-2209-232-N00		19-9	D-2220-K1A-A00		26-46	D-2516-322-J00		26-25	D-2524-232-M00		27-48
B-LKSUB00006		15-15	D-2209-232-P00		19-21	D-2220-K1A-A00		26-21	D-2516-232-M00		19-18	D-2524-232-M00		22-33
B-LKSUB00006		25-16	D-2209-232-Q00		19-30	D-2220-K1A-A00		28-17	D-2516-232-M00		22-20	D-2524-K0R-R00		20-30
B-LKSUB00007		15-30	D-2209-232-S00		19-44	D-2401-322-J00		26-35	D-2516-232-M00		23-24	D-2524-K0R-R00		21-8
B-LKSUB00008		16-1	D-2209-232-U00		20-29	D-2423-232-C00		12-16	D-2516-232-S00		19-5	D-2524-K7R-Y00		16-4
B-LKSUB00008		26-8	D-2209-232-V00		21-19	D-2423-232-C00		24-19	D-2516-232-S00		19-34	D-2524-K7R-Y00		18-9
B-LKSUB00009		17-1	D-2209-232-W00		21-30	D-2423-232-C00		26-14	D-2516-232-S00		22-37	D-2524-K7R-Y00		21-32
B-LKSUB00009		26-23	D-2209-232-Z00		22-17	D-2423-232-C00		26-30	D-2516-232-S00		23-6	D-2524-232-U00		20-25
B-LKSUB00010		17-14	D-2209-322-D00		25-9	D-2423-232-C00		28-7	D-2516-232-T00		20-11	D-2524-K7R-U00		23-20
B-LKSUB00011		18-1	D-2209-322-E00		25-15	D-2433-232-C00		28-26	D-2516-232-U00		20-21	D-2524-K7R-U00		19-13
B-LKSUB00012		18-10	D-2209-322-F00		25-23	D-2426-232-B00		12-3	D-2516-232-U00		21-6	D-2525-232-D00		14-35
B-LKSUB00013		19-1	D-2209-322-V00		27-22	D-2426-232-B00		24-12	D-2516-K7A-C00		28-34	D-2525-232-K00		17-18
B-LKSUB00014		19-14	D-2209-322-H00		26-20	D-2426-232-E00		12-15	D-2517-232-B00		12-6	D-2525-232-K00		27-6
B-LKSUB00015		19-25	D-2209-322-J00		26-45	D-2426-232-E00		13-18	D-2517-232-B00		24-13	D-2526-232-B00		12-9
B-LKSUB00017		19-31	D-2209-K0A-E00		22-28	D-2426-232-E00		15-3	D-2517-232-C00		12-19	D-2526-232-B00		12-27
B-LKSUB00018		20-1	D-2209-K0A-F00		22-34	D-2426-232-E00		15-17	D-2517-232-C00		24-18	D-2526-232-B00		13-19
B-LKSUB00019		20-17	D-2209-K0A-Q00		23-1	D-2426-K9S-E00		15-32	D-2517-232-C0A		12-(22)	D-2526-232-B00		24-*28
B-LKSUB00020		21-1	D-2209-K0A-L00		22-47	D-2426-232-E00		17-3	D-2517-232-C0A		24-(23)	D-2526-232-E00		15-8
B-LKSUB00020		27-2	D-2209-K0A-T00		23-11	D-2426-232-E00		17-16	D-2517-232-D00A		14-28	D-2526-232-F00		15-22
B-LKSUB00021		21-20	D-2209-K0A-U00		23-27	D-2426-232-E00		18-2	D-2517-232-E00		15-4	D-2526-232-F00		17-31
B-LKSUB00022		22-1	D-2209-K1A-M00		28-19	D-2426-232-E00		18-11	D-2517-232-F00		15-18	D-2526-232-G00		15-37
B-LKSUB00024		22-11	D-2209-K1A-P00		28-39	D-2426-232-E00		24-17	D-2517-232-G00		15-33	D-2526-232-G00		27-37
B-LKSUB00025		27-28	D-2209-K1A-A00		27-40	D-2426-232-E00		25-5	D-2517-232-G0B		15-50	D-2526-232-L00		17-7
B-LKSUB00029		22-18	D-2211-232-B00		12-10	D-2426-232-E00		25-17	D-2517-232-G0C		15-53	D-2526-322-D00		25-7
B-LKSUB00035		22-35	D-2211-232-B00		12-28	D-2426-232-E00		27-4	D-2517-232-J00		17-4	D-2526-322-D00		25-19
B-LKSUB00036		28-2	D-2211-232-B00		13-17	D-2426-232-E00		27-30	D-2517-232-K00		17-20	D-2526-322-V00		27-24
B-LKSUB00038		28-22	D-2211-232-B00		16-10	D-2426-232-E00		16-6	D-2517-232-K00		27-8	D-2526-232-E00		28-27
B-LKSUB00042		23-2	D-2211-232-B00		15-11	D-2426-232-E00		19-2	D-2517-232-L00		18-3	D-2526-232-E00		23-25
B-LKSUB00043		23-13	D-2211-232-B00		15-25	D-2426-232-E00		19-15	D-2517-232-M00		18-12	D-2526-232-F00		22-29
			D-2211-232-B00		15-40	D-2426-232-E00		19-32	D-2517-322-D00		25-4	D-2526-232-G00		26-16
			D-2211-232-B00		17-30	D-2426-232-E00		20-2	D-2517-322-F00		25-22	D-2526-232-H00		16-10
			D-2211-232-B00		16-11	D-2426-232-E00		20-18	D-2517-322-F0B		25-(30)	D-2523-232-K00		26-36
			D-2211-232-B00		19-28	D-2426-232-E00		21-2	D-2517-322-V00		27-(26)	D-2526-232-V00		22-43
			D-2211-232-B00		21-31	D-2426-232-E00		21-22	D-2517-K1A-A00		27-36	D-2526-322-D00		19-10
			D-2211-232-B00		23-26	D-2426-232-E00		22-19	D-2517-232-H00		16-7	D-2526-322-D00		21-26
			D-2211-K1A-M00		28-16	D-2426-K9S-E00		22-36	D-2517-322-H00		21-25	D-2526-322-D00		28-8
			D-2214-232-B00		12-11	D-2426-232-E00		23-3	D-2517-322-H00		26-13	D-2526-322-J00		26-34
			D-2214-232-B00		12-29	D-2426-232-E00		23-15	D-2517-322-J00		26-41	D-2526-322-V00		19-41
			D-2214-232-B00		13-20	D-2426-232-E00		26-3	D-2517-322-J0B		26-41	D-2526-322-V00		20-12
			D-2214-232-B00		15-10	D-2426-232-E00		28-4	D-2517-322-J0C		26-41	D-2526-322-V00		21-16
			D-2214-232-B00		15-24	D-2426-232-E00		28-23	D-2517-232-N00		19-11	D-2526-322-V00		22-15
			D-2214-232-B00		15-39	D-2426-322-J00		26-27	D-2517-232-N0B		19-13	D-2527-232-D00		14-30
			D-2214-232-B00		17-9	D-2426-232-X00		22-2	D-2517-232-P00		19-22	D-2528-232-D00		14-29
			D-2214-232-B00		17-28	B-2429-232-000		22-9	D-2517-232-S00		19-36	D-2529-232-D00		14-34
			D-2214-232-B00		16-13	D-2501-232-D00		14-18	D-2517-232-S0B		19-(45)	D-2530-232-B00		12-7
			D-2214-232-B00		19-27	D-2502-232-D00		14-17	D-2517-232-T00		20-8	D-2530-232-B00		12-24
			D-2214-232-B00		21-29	D-2504-232-DA0		14-16	D-2517-232-U00		20-22	D-2530-232-B00		13-9
			D-2214-232-B00		23-16	D-2505-282-AA0		14-32	D-2517-232-V00		21-15	D-2530-232-B00		15-13
			D-2214-232-B00		28-18	D-2506-232-D00		14-20	D-2517-232-X00		22-9	D-2530-232-B00		15-27
			D-2220-232-K00		15-44	D-2507-232-D00		14-7	D-2517-232-Z00		22-14	D-2530-232-B00		15-42
			D-2220-232-K00		17-32	D-2509-232-D00		14-3	D-2517-K0A-E00		22-32	D-2530-232-B00		17-12
			D-2220-232-K00		16-33	D-2510-232-D00		14-8	D-2517-K0A-L00		22-46	D-2530-232-B00		17-34
			D-2220-232-K00		18-20	D-2511-232-D00		14-1	D-2517-K0A-T00		23-9	D-2530-232-B00		18-15
			D-2220-232-K00		18-21	D-2512-232-D00		14-2	D-2517-K0A-U00		23-23	D-2530-232-B00		24-*26
			D-2220-232-K00		16-16	D-2512-232-K00		17-24	D-2517-K1A-M00		28-11	D-2530-232-B00		25-11
			D-2220-232-K00		19-4	D-2512-232-K00		27-14	D-2517-K1A-P00		28-32	D-2530-232-B00		25-26
			D-2220-232-K00		19-17	D-2513-232-DA0		14-11	D-2519-232-D00		14-23	D-2530-232-B00		27-12
			D-2220-232-K00		19-29	D-2514-232-D00		14-14	D-2519-232-K00		17-27	D-2530-232-B00		27-31
			D-2220-232-K00		19-43	D-2515-232-D00		14-13	D-2519-232-K00		27-15	D-2530-232-B00		19-6
			D-2220-232-K00		20-15	D-2516-322-D00		19-8	D-2519-232-K00		28-12	D-2530-232-B00		19-19
			D-2220-232-K00		20-28	D-2516-232-DA0		14-4	D-2520-232-DA0		14-27			
						D-2516-232-E00		15-7						
						D-2516-232-E00		15-21						

Part No.	Page	Ref. No.	Part No.	Page	Ref. No.	Part No.	Page	Ref. No.	Part No.	Page	Ref. No.	Part No.	Page	Ref. No.
D-2530-232-B00	19-40		D-2550-232-V00	21-13		D-2580-322-J00	26-41		SD-0550271-TP	14-22		SS-6151920-SP		1-1
D-2530-232-B00	20-4		D-2550-232-VA0	21-*		D-2580-322-J0B	26-41		SD-0640241-SP	8-10		SS-6201940-SP		3-12
D-2530-232-B00	20-19		D-2550-232-X00	22-5		D-2580-322-J0C	26-41		SD-0720193-SP	2-31j		SS-6241640-SP		10-20
D-2530-232-B00	21-4		D-2550-232-XA0	22-*		D-2581-322-J00	26-38		SD-0790303-SP	4-29		SS-6242540-SP		10-21
D-2530-232-B00	22-25		D-2550-232-Z00	22-13		D-2580-K1A-P00	28-30		SD-0790303-SP	5-17		SS-7080310-SP		7-13
D-2530-232-B00	26-4		D-2550-232-ZA0	22-*		D-3128-K9S-E00	22-53		SD-0790303-SP	13-14		SS-7080410-SP		2-26
D-2530-232-B00	26-28		D-2550-322-D00	25-3		D-7101-232-X00	22-10		SD-0790511-SP	1-17		SS-7080510-SP		3-56
D-2539-K7R-W00	16-17		D-2550-322-F00	25-21		D-7101-232-X00	22-42		SD-0800351-SP	1-32		SS-7080510-SP		8-28
D-2541-232-GA0	15-45		D-2550-322-F00	25-(29)		D-7101-232-X00	23-10		SD-0800352-SP	1-22		SS-7090510-SP		5-36
D-2541-232-GA0	25-37		D-2550-322-V00	27-(25)		D-7101-K1A-P00	28-15		SD-0800553-SP	4-11		SS-7090510-SP		26-9
D-2541-232-GA0	27-44		D-2550-322-H00	26-12		D-7102-232-X00	28-33		SD-0850751-SP	8-30		SS-7090520-TP		6-13
D-2541-232-GA0	27-46		D-2550-322-HA0	26-*		D-7102-232-X00	22-10		SD-0950491-SP	17-25		SS-7090910-SP		1-10
D-2541-K0R-TA0	16-3		D-2550-322-J00	26-39		D-7102-232-X00	22-42		SD-0950491-SP	27-16		SS-7090910-SP		10-10
D-2541-232-GA0	19-35		D-2550-322-J0B	26-39		D-7102-232-X00	23-10		SD-0950491-SP	28-13		SS-7091110-TP		3-48
D-2541-232-GA0	20-6		D-2550-322-J0C	26-39		D-7102-232-X00	28-15		SD-1030931-SP	5-54		SS-7091110-TP		4-19
D-2541-232-GA0	21-7		D-2550-322-J0D	26-39		D-7102-K1A-P00	28-33					SS-7091110-SP		5-8
D-2541-232-GA0	22-16		D-2550-322-J0E	26-39		D-2580-232-D00	14-9					SS-7110710-SP		1-13
D-2541-232-GA0	22-38		D-2550-K0A-E00	22-31		D-9140-322-J00	26-43					SS-7110710-SP		1-42
D-2541-232-GA0	26-6		D-2550-K0A-EA0	22-*					SCREW			SS-7110710-SP		13-6
D-2545-232-D0A	14-12		D-2550-K0A-L00	22-45					SS-1110640-SP	14-33		SS-7110710-SP		1-42
D-2545-232-N00	20-14		D-2550-K0A-LA0	22-*					SS-1110640-TP	7-1		SS-7110740-TP		5-22
D-2545-232-N00	20-27		D-2550-K0A-T00	23-8		MLQ-500B1800	3-50		SS-1110640-TP	8-5		SS-7110820-SP		15-48
D-2545-232-N00	21-18		D-2550-K0A-TA0	23-*					SS-1110810-SP	8-25		SS-7110820-SP		17-24
D-2546-232-D00	13-10		D-2550-K1A-M00	28-10					SS-2060220-SP	7-2		SS-7110820-SP		21-12
D-2546-232-K00	17-21		D-2550-K1A-MA0	28-*		NS-2820850-SD	4-36		SS-2060310-SP	2-18		SS-7110820-SP		22-23
D-2546-232-K00	27-9		D-2550-K1A-P00	28-29		NS-6090310-SP	10-11		SS-2060410-SP	2-4		SS-7110820-SP		22-40
D-2546-232-K00	26-42		D-2550-K1A-PA0	28-*		NS-6110310-SP	2-31f		SS-2090520-SL	2-21		SS-7110820-SP		23-18
D-2547-232-D00	13-15		D-2551-232-B00	12-4		NS-6110310-SP	2-31m		SS-2110920-TP	7-17		SS-7110840-SP		2-37
D-2548-232-D00	14-6		D-2551-232-B00	24-10		NS-6110310-SP	2-35f		SS-2110920-TP	3-36		SS-7110860-SP		5-26
D-2549-232-D00	13-13		D-2551-232-C00	12-17		NS-6110530-SP	1-4		SS-2110930-SP	2-11		SS-7110860-SP		7-20
D-2550-232-B00	12-5		D-2551-232-C00	24-15		NS-6110530-SP	5-20		SS-2111140-SP	8-3		SS-7110910-SP		2-31g
D-2550-232-BA0	12-*		D-2551-232-C0A	12-(20)		NS-6110530-SP	14-10		SS-3060410-SP	9-34		SS-7111110-TP		9-31
D-2550-232-B00	24-11		D-2551-232-C0A	24-(21)		NS-6120310-SP	2-31p		SS-3090610-SP	2-30		SS-7111120-SP		5-11
D-2550-232-C00	12-18		D-2551-232-E00	15-5		NS-6120310-SP	5-45		SS-3090610-SP	9-9		SS-7111120-SP		10-24
D-2550-232-CA0	12-*		D-2551-232-F00	15-19		NS-6120480-SP	7-26		SS-4080310-SP	28-31		SS-7111310-SP		5-38
D-2550-232-C00	24-16		D-2551-232-G00	15-34		NS-6150310-SP	4-13		SS-5060310-SP	3-52		SS-7120910-SP		4-37
D-2550-232-C0A	12-(21)		D-2551-232-G0B	15-52		NS-6150310-SP	10-31		SS-5150540-SP	3-43		SS-7151120-SP		10-2
D-2550-232-C0A	24-(22)		D-2551-232-G0C	15-55		NS-6150430-SP	9-17		SS-6060340-SP	5-25h		SS-7151210-SK		4-25
D-2550-232-E00	15-6		D-2551-232-H00	27-34		NS-6150440-SP	11-4		SS-6080410-SP	22-8		SS-7151210-SP		1-7
D-2550-232-EA0	15-*		D-2551-232-H00	15-52		NS-6150540-SP	7-32		SS-6080610-TP	5-40		SS-7151210-SP		6-1
D-2550-232-F00	15-20		D-2551-232-H00	21-23		NS-6150540-SP	6-23		SS-6080610-TP	7-31		SS-7151210-SP		9-13
D-2550-232-FA0	15-*		D-2551-232-J00	17-5		NS-6200710-SP	11-6		SS-6080810-SP	5-6		SS-7151210-SP		11-23
D-2550-232-G00	15-35		D-2551-232-L00	18-4		NS-6200710-SP	14-21		SS-6090420-SP	4-42		SS-7151330-SP		10-32
D-2550-232-G0B	15-51		D-2551-232-M00	18-13		NS-6240630-SP	10-44		SS-6090440-SP	12-23		SS-7151330-SP		11-3
D-2550-232-G0C	15-54		D-2551-232-N00	19-13		NS-6361040-SP	6-21		SS-6090440-SP	15-9		SS-7151330-SP		11-14
D-2550-232-GA0	15-*		D-2551-232-N0B	19-13		NS-6620310-SP	5-18		SS-6090440-SP	15-23		SS-7151330-SP		12-8
D-2550-232-H00	27-35		D-2551-232-N0B	19-13		NS-6620310-SP	10-37		SS-6090440-SP	15-38		SS-7151330-SP		12-25
D-2550-232-H00	17-6		D-2551-232-H00	16-9		NS-6660430-SP	5-53		SS-6090440-SP	17-8		SS-7151330-SP		13-8
D-2550-232-JA0	17-*		D-2551-232-H00	21-23		NS-6660430-SP	17-26		SS-6090440-SP	18-19		SS-7151330-SP		15-14
D-2550-232-K00	16-19		D-2551-232-P00	19-24		NS-6660430-SP	20-17		SS-6090440-SP	24-20		SS-7151330-SP		15-28
D-2550-232-K00	27-7		D-2551-232-S00	19-38		NS-6660430-SP	28-14		SS-6090440-SP	25-6		SS-7151330-SP		15-43
D-2550-232-L00	18-5		D-2551-232-S0B	19-(47)					SS-6090440-SP	25-25		SS-7151330-SP		17-13
D-2550-232-M00	18-14		D-2551-232-T00	20-10					SS-6080652-TP	26-37		SS-7151330-SP		17-35
D-2550-232-H00	21-24		D-2551-232-U00	20-24		PIN			SS-6090440-SP	19-3		SS-7151330-SP		18-16
D-2550-232-HA0	16-*		D-2551-232-V00	21-14		PD-0201000-0B	13-11		SS-6090440-SP	19-16		SS-7151330-SP		19-7
D-2550-232-HA0	21-*		D-2551-232-V00	21-14		PS-0200082-K0	13-12		SS-6090440-SP	19-33		SS-7151330-SP		19-39
D-2550-232-H00	16-8		D-2551-232-X00	22-4		PS-0500202-KP	4-15		SS-6090440-SP	20-3		SS-7151330-SP		19-20
D-2550-232-N00	19-12		D-2551-232-X00	22-12		PT-0251800-SH	3-23		SS-6090440-SP	21-3		SS-7151330-SP		20-5
D-2550-232-N0B	19-13		D-2551-232-Z00	22-12		PT-0301600-S0	5-48		SS-6090440-SP	22-21		SS-7151330-SP		20-20
D-2550-232-NA0	19-*		D-2551-322-D00	25-2		PT-0302000-S0	3-3		SS-6090440-SP	23-4		SS-7151330-SP		21-5
D-2550-232-P00	19-23		D-2551-322-F00	25-20		PT-0401800-S0	3-1		SS-6090440-SP	26-15		SS-7151330-SP		22-26
D-2550-232-P00	19-*		D-2551-322-F0B	25-(28)		PT-0401800-S0	6-11		SS-6090440-SP	26-26		SS-7151330-SP		26-5
D-2550-232-S00	19-37		D-2551-322-H00	26-11		PT-0402200-C0	3-30		SS-6090510-SP	7-6		SS-7151330-SP		26-29
D-2550-232-S0B	19-(46)		D-2551-322-H00	26-40		PT-0503200-SH	6-5		SS-6091210-TP	3-54		SS-7151330-SP		24-27
D-2550-232-SA0	19-*		D-2551-K0A-E00	22-30					SS-6111010-TP	4-4		SS-7151330-SP		25-12
D-2550-232-TA0	20-*		D-2551-K0A-L00	22-44		RUBBER RING			SS-6111040-SP	5-16		SS-7151330-SP		25-27
D-2550-232-T00	20-9		D-2551-K0A-L00	22-44		RE-0600000-K0	6-9		SS-6111040-SP	11-9		SS-7151330-SP		27-13
D-2550-232-U00	20-23		D-2551-K0A-T00	23-7		RE-0700000-K0	14-15		SS-6111140-SP	5-3		SS-7151330-SP		27-32
D-2550-232-UA0	20-*		D-2551-K0A-U00	23-22					SS-6111610-SP	5-19		SS-7161040-SP		7-10
			D-2551-K1A-M00	28-9		HINGE SCREW			SS-6121212-TP	5-27		SS-7681750-TP		3-25
			D-2551-K1A-P00	28-28		SD-0400841-SP	5-10		SS-6151142-TP	7-36		SS-8090870-SP		2-14
			D-2552-322-H00	26-10		SD-0480251-SP	8-8		SS-6151780-SP	9-24				
			D-2555-232-X00	22-9		SD-0500803-SL	5-25e							
			D-2556-322-J00	26-41		SD-0550271-TP	4-40							

Part No.	Page	Ref. No.
SS-8110410-TP	5-47	
SS-8110520-TP	5-51	
SS-8150410-TP	3-42	
SS-8150410-SP	4- 6	
SS-8150410-TP	9-16	
SS-8150710-SP	3-27	
SS-8150710-SP	5-49	
SS-8150710-SP	9-14	
SS-8150760-TP	3-15	
SS-8151150-TP	6- 7	
SS-8151150-TP	6-18	
SS-8151150-SP	10- 9	
SS-8151550-SP	10-29	
SS-8660530-TP	5-56	
SS-8660610-TP	3-28	
SS-8701140-SP	3-21	
SS-9110460-CP	8-22	
SS-9110463-CP	8-21	
SS-9110543-SP	8-23	
SS-9110543-SP	14- 5	
SS-9110543-CP	17-36	
SS-9110543-CP	27-45	
SS-9110920-CP	7-14	
SS-9202443-CP	11-15	
SS-9202443-SP	11-18	
SS-9150730-SP	14-36	
SS-9150880-SP	4-31	
SS-9151120-CP	5-21	
SS-9151120-CP	8-18	
SS-9151120-CP	11-16	
SS-9151160-CP	14-19	
SS-9151440-CP	8-11	
SS-9151630-CP	4-22	
SS-9151630-CP	6- 3	
SS-9151630-CP	7-24	
SS-9151630-CP	9-33	
SS-9151630-CP	10- 5	
SS-9151630-CP	11-11	
SS-9152130-CP	4-14	
SS-9152130-SP	10-19	

WASHER

WS-0451040-KP	7-15
WP-0480856-SP	2-36
WP-0480856-SP	13- 7
WP-0501016-SD	1- 5
WP-0501016-SD	5-44
WP-0501016-SD	7-27
WP-0612056-SD	10-34
WP-0612056-SD	11- 2
WP-0612516-SD	8-12
WP-0612516-SD	10-18
WP-0612516-SD	11-10
WP-0621016-SD	4-16
WP-0621016-SD	4-23
WP-0621016-SD	6- 6
WP-0621016-SD	7-25
WP-0621016-SD	7-33
WP-0621016-SD	8-19
WP-0621016-SD	9-18
WP-0621016-SD	9-18A
WP-0651056-SD	4-26
WP-0850002-SD	1-19